

City of Hillsdale

2012 International Property Maintenance Code Book



CHAPTER 1

SCOPE AND ADMINISTRATION

PART 1 — SCOPE AND APPLICATION

SECTION 101
GENERAL

[A] **101.1 Title.** These regulations shall be known as the *International Property Maintenance Code of the City of Hillsdale*. Hereinafter referred to as "this code."

[A] **101.2 Scope.** The provisions of this code shall apply to all existing residential and nonresidential structures and all existing *premises* and constitute minimum requirements and standards for *premises*, structures, equipment and facilities for light, *ventilation*, space, heating, sanitation, protection from the elements, life safety, safety from fire and other hazards, and for safe and sanitary maintenance; the responsibility of *owners, operators and occupants*, the *occupancy* of existing structures and *premises*, and for administration, enforcement and penalties.

[A] **101.3 Intent.** This code shall be construed to secure its expressed intent, which is to ensure public health, safety and welfare insofar as they are affected by the continued *occupancy* and maintenance of structures and premises. Existing structures and *premises* that do not comply with these provisions shall be altered or repaired to provide a minimum level of health and safety as required herein.

[A] **101.4 Severability.** If a section, subsection, sentence, clause or phrase of this code is, for any reason, held to be unconstitutional, such decision shall not affect the validity of the remaining portions of this code.

SECTION 102
APPLICABILITY

[A] **102.1 General.** Where there is a conflict between a general requirement and a specific requirement, the specific requirement shall govern. Where differences occur between provisions of this code and the referenced standards, the provisions of this code shall apply. Where, in a specific case, different sections of this code specify different requirements, the most restrictive shall govern.

[A] **102.2 Maintenance.** Equipment, systems, devices and safeguards required by this code or a previous regulation or code under which the structure or premises was constructed, altered or repaired shall be maintained in good working order. No owner, operator or occupant shall cause any service, facility, equipment or utility which is required under this section to be removed from or shut off from or discontinued for any occupied dwelling, except for such temporary interruption as necessary while repairs or alterations are in progress. The requirements of this code are not intended to provide the basis for removal or abrogation of fire protection and safety systems and devices in existing structures.

Except as otherwise specified herein, the owner or the owner's designated agent shall be responsible for the maintenance of buildings, structures and premises.

[A] **102.3 Application of other codes.** Repairs, additions or alterations to a structure, or changes of occupancy, shall be done in accordance with the procedures and provisions of the International Building Code, International Energy Conservation Code, International Fire Code, International Fuel Gas Code, International Mechanical Code, International Residential Code, International Plumbing Code and NFPA 70. Nothing in this code shall be construed to cancel, modify or set aside any provision of the International Zoning Code.

[A] **102.4 Existing remedies.** The provisions in this code shall not be construed to abolish or impair existing remedies of the jurisdiction or its officers or agencies relating to the removal or demolition of any structure which is dangerous, unsafe and insanitary.

[A] **102.5 Workmanship.** Repairs, maintenance work, alterations or installations which are caused directly or indirectly by the enforcement of this code shall be executed and installed in a workmanlike manner and installed in accordance with the manufacturer's instructions.

[A] **102.6 Historic buildings.** The provisions of this code shall not be mandatory for existing buildings or structures designated as historic buildings when such buildings or structures are judged by the code official to be safe and in the public interest of health, safety and welfare.

[A] **102.7 Referenced codes and standards.** The codes and standards referenced in this code shall be those that are listed in Chapter 8 and considered part of the requirements of this code to the prescribed extent of each such reference and as further regulated in Sections 102.7.1 and 102.7.2.

Exception: Where enforcement of a code provision would violate the conditions of the listing of the equipment or appliance, the conditions of the listing shall apply.

[A] **102.7.1 Conflicts.** Where conflicts occur between provisions of this code and the referenced standards, the provisions of this code shall apply.

[A] **102.7.2 Provisions in referenced codes and standards.** Where the extent of the reference to a referenced code or standard includes subject matter that is within the scope of this code, the provisions of this code, as applicable, shall take precedence over the provisions in the referenced code or standard.

[A] **102.8 Requirements not covered by code.** Requirements necessary for the strength, stability or proper operation of an existing fixture, structure or equipment, or for the public safety, health and general welfare, not specifically covered by this code, shall be determined by the code official.

[A] **102.9 Application of references.** References to chapter or section numbers, or to provisions not specifically identified by number, shall be construed to refer to such chapter, section or provision of this code.

[A] **102.10 Other laws.** The provisions of this code shall not be deemed to nullify any provisions of local, state or federal law.

PART 2 — ADMINISTRATION AND ENFORCEMENT

**SECTION 103
CODE ENFORCEMENT OFFICE**

[A] **103.1 General.** *The Code Enforcement Office, a subsection of the Planning/Assessing Department, shall be responsible for the enforcement of the 2012 International Property Maintenance Code and the Administrator in charge thereof shall be known as the Code Official.*

[A] **103.2 Appointment.** *The Code Official shall be appointed by the City Manager.*

[A] **103.3 Deputies.** In accordance with the prescribed procedures of this jurisdiction and with the concurrence of the appointing authority, the code official shall have the authority to appoint a deputy(s). Such employees shall have powers as delegated by the code official.

[A] **103.4 Liability.** The code official, member of the board of appeals or employee charged with the enforcement of this code, while acting for the jurisdiction, in good faith and without malice in the discharge of the duties required by this code or other pertinent law or ordinance, shall not thereby be rendered liable personally, and is hereby relieved from all personal liability for any damage accruing to persons or property as a result of an act or by reason of an act or omission in the discharge of official duties. Any suit instituted against any officer or employee because of an act performed by that officer or employee in the lawful discharge of duties and under the provisions of this code shall be defended by the legal representative of the jurisdiction until the final termination of the proceedings. The code official or any subordinate shall not be liable for costs in an action, suit or proceeding that is instituted in pursuance of the provisions of this code.

[A] **103.5 Fees.** The fees for activities and services performed by the department in carrying out its responsibilities under this code shall be as indicated in the following schedule.

**SECTION 104
DUTIES AND POWERS OF THE CODE OFFICIAL**

[A] **104.1 General.** The code official is hereby authorized and directed to enforce the provisions of this code. The code official shall have the authority to render interpretations of this code and to adopt policies and procedures in order to clarify the application of its provisions. Such interpretations, policies and procedures shall be in compliance with the intent and purpose of this code. Such policies and procedures shall not have the effect of waiving requirements specifically provided for in this code.

[A] **104.2 Inspections.** The code official shall make all of the required inspections, or shall accept reports of inspection by approved agencies or individuals. All reports of such inspections shall be in writing and be certified by a responsible officer of such approved agency or by the responsible individual. The code official is authorized to engage such expert opinion as deemed necessary to report upon unusual technical issues that arise, subject to the approval of the appointing authority.

[A] **104.3 Right of entry.** Where it is necessary to make an inspection to enforce the provisions of this code, or whenever the code official has reasonable cause to believe that there exists in a structure or upon a premises a condition in violation of this code, the code official is authorized to enter the structure or premises at reasonable times to inspect or perform the duties imposed by this code, provided that if such structure or premises is occupied the code official shall present credentials to the occupant and request entry. If such structure or premises is unoccupied, the code official shall first make a reasonable effort to locate the owner or other person having charge or control of the structure or premises and request entry. If entry is refused, the code official shall have recourse to the remedies provided by law to secure entry.

[A] **104.4 Identification** The code official shall carry proper identification when inspecting structures or premises in the performance of duties under this code.

[A] **104.5 Notices and orders.** The code official shall issue all necessary notices or orders to ensure compliance with this code.

[A] **104.6 Department records.** The code official shall keep official records of all business and activities of the department specified in the provisions of this code. Such records shall be retained in the official records for the period required for retention of public records.

SECTION 105 APPROVAL

[A] **105.1 Modifications.** Whenever there are practical difficulties involved in carrying out the provisions of this code, the code official shall have the authority to grant modifications for individual cases upon application of the owner or owner's representative, provided the code official shall first find that special individual reason makes the strict letter of this code impractical and the modification is in compliance with the intent and purpose of this code and that such modification does not lessen health, life and fire safety requirements. The details of

SCOPE AND ADMINISTRATION

action granting modifications shall be recorded and entered in the department files.

[A] 105.2 Alternative materials, methods and equipment. The provisions of this code are not intended to prevent the installation of any material or to prohibit any method of construction not specifically prescribed by this code, provided that any such alternative has been approved. An alternative material or method of construction shall be approved where the code official finds that the proposed design is satisfactory and complies with the intent of the provisions of this code, and that the material, method or work offered is, for the purpose intended, at least the equivalent of that prescribed in this code in quality, strength, effectiveness, fire resistance, durability and safety.

[A] 105.3 Required testing. Whenever there is insufficient evidence of compliance with the provisions of this code, or evidence that a material or method does not conform to the requirements of this code, or in order to substantiate claims for alternative materials or methods, the code official shall have the authority to require tests to be made as evidence of compliance at no expense to the jurisdiction.

[A] 105.3.1 Test methods. Test methods shall be as specified in this code or by other recognized test standards. In the absence of recognized and accepted test methods, the code official shall be permitted to approve appropriate testing procedures performed by an approved agency.

[A] 105.3.2 Test reports. Reports of tests shall be retained by the code official for the period required for retention of public records.

[A] 105.4 Used material and equipment. The use of used materials which meet the requirements of this code for new materials is permitted. Materials, equipment and devices shall not be reused unless such elements are in good repair or have been reconditioned and tested when necessary, placed in good and proper working condition and approved by the code official.

[A] 105.5 Approved materials and equipment. Materials, equipment and devices approved by the code official shall be constructed and installed in accordance with such approval.

[A] 105.6 Research reports. Supporting data, where necessary to assist in the approval of materials or assemblies not specifically provided for in this code, shall consist of valid research reports from approved sources.

SECTION 106 VIOLATIONS

[A] 106.1 Unlawful acts. It shall be unlawful for a person, firm or corporation to be in conflict with or in violation of any of the provisions of this code.

[A] 106.2 Notice of violation. The code official shall serve a notice of violation or order in accordance with Section 107.

[A] 106.3 Prosecution of violation. *Any person failing to comply with a notice of violation or order served in accordance with Section 107 shall be deemed responsible for a municipal civil infraction, and the violation shall be deemed a strict liability offense. If the notice of violation is not completely complied with, the code official is authorized and empowered to issue a municipal civil infraction citation and to institute appropriate action through the office of the city attorney to obtain an order from a court of competent jurisdiction in a proceeding at law or in equity to: authorize entry to inspect a building, structure, or premises; restrain, correct or abate such violation; require the removal or termination of the unlawful occupancy of the building, structure, or premises; or to stop an illegal act, conduct, business, or utilization of such building, structure, or premises. The costs associated with any action taken by the code official shall be charged against the real estate upon which the building, structure, or premises is located and shall be a lien upon such real estate.*

[A] 106.4 Violation penalties. *Correction of violations: Any person who shall violate or fail to comply with a provision of this code, or who fails to comply with its requirements, including but not limited to those cited in a notice of violation or order served in accordance with Section 107, shall be deemed responsible for a municipal civil violation together with such penalties and costs as are assessable and charged pursuant to Chapter 20 of Code of Ordinances of the City of Hillsdale, the provisions of this code, and other applicable law.*

[A] 106.5 Abatement of violation. *Irrespective of whether penalties and costs are imposed or paid, in the event a violation determined by a court of competent jurisdiction is not corrected as ordered, the code official may order such violations corrected by the appropriate department or agency of the city that is qualified to do the work required, or may do the work by contract or hire. Any unpaid penalties and costs that are imposed and the cost of the correction of the violation, including reasonable administrative costs, shall be assessed and levied upon the property upon which such violation is located. The imposition of the penalties herein prescribed shall not preclude the code official from suspending, revoking or taking other administrative action permitted by law with respect to a related license or permit, nor shall it preclude the code official from instituting appropriate action through the office of the city attorney to obtain an order from a court of competent jurisdiction in a proceeding at law or in equity to: authorize entry to inspect a building, structure, or premises; restrain, correct or abate such violation; require the removal or termination of the unlawful occupancy of the building, structure, or premises; or to stop an illegal act, conduct, business, or utilization of such building, structure, or premises.*

[A] 106.5.1 Assessment and collection of penalties and costs. *Any penalties and costs, including administrative costs, that are incurred and imposed by reason of any violation or in conjunction with any action taken or instituted by the code official to secure its restraint, correction, or abatement, shall be assessed and levied upon the property upon which the violation was located if not paid within 30 days of the date such penalties and costs are charged or billed to the property owner. All such penalties and costs shall constitute a lien upon the property and*

shall be collected at the same time and in the same manner as are regular city taxes, and shall be subject to the same penalties as are levied for unpaid property taxes.

**SECTION 107
NOTICES AND ORDERS**

[A] 107.1 Notice to person responsible. Whenever the code official determines that there has been a violation of this code or has grounds to believe that a violation has occurred, notice shall be given in the manner prescribed in Sections 107.2 and 107.3 to the person responsible for the violation as specified in this code. Notices for condemnation procedures shall also comply with Section 108.3.

[A] 107.2 Form. Such notice prescribed in Section 107.1 shall be in accordance with all of the following:

1. Be in writing.
2. Include a description of the real estate sufficient for identification.
3. Include a statement of the violation or violations and why the notice is being issued.
4. Include a correction order allowing a reasonable time to make the repairs and improvements required to bring the dwelling unit or structure into compliance with the provisions of this code.
5. Inform the property owner of the right to appeal.
6. Include a statement of the right to file a lien in accordance with Section 106.3.

[A] 107.3 Method of service. Such notice shall be deemed to be properly served if a copy thereof is:

1. Delivered personally;
2. Sent by certified or first-class mail addressed to the last known address; or
3. If the notice is returned showing that the letter was not delivered, a copy thereof shall be posted in a conspicuous place in or about the structure affected by such notice.

[A] 107.4 Unauthorized tampering. Signs, tags or seals posted or affixed by the code official shall not be mutilated, destroyed or tampered with, or removed without authorization from the code official.

[A] 107.5 Penalties. *Penalties for noncompliance with orders and notices shall be as set forth in Section 106.4, 106.5 and 106.5.1*

[A] 107.6 Transfer of ownership. *It shall be unlawful for the owner of any dwelling unit or structure who has received a compliance order or upon whom a notice of violation has been served to sell, transfer, mortgage, lease or otherwise dispose of such dwelling unit or structure, or any possessory interest therein, to another individual or entity until the provisions of the compliance order or notice of violation have been complied with, or until such owner shall first furnish the individual or entity to whom the dwelling unit or structure is proposed to be sold, transferred, mortgaged, leased, or otherwise disposed of with a true copy of each such compliance order or notice of violation issued with regard to the dwelling unit or structure, and such owner shall also furnish to the code official, on a form available from and provided by the code official, a signed and notarized statement by the individual or authorized representative of any entity to whom the dwelling unit or structure is proposed to be sold, transferred, mortgaged, leased, or otherwise disposed of, acknowledging the receipt of such compliance order or notice of violation and fully accepting the responsibility without condition for making all required corrections or repairs identified in the compliance order or notice of violation.*

107.6.1 *With respect to corrections or repairs cited as being necessary in a notice of violation that has not yet been placed before a court for enforcement, there shall not be any extension of time within which any grantee, transferee, mortgagee or lessee is to complete the corrections or repairs cited therein unless requested by the grantee, transferee, mortgagee or lessee and approved by the code official in writing.*

107.6.2 *With respect to corrections or repairs ordered by the court in which a violation is being or has been adjudicated, there shall not be any extension of time within which any grantee, transferee, mortgagee or lessee is to complete the corrections or repairs cited therein except upon the written petition by the grantee, transferee, mortgagee or lessee to such court and a court order allowing it.*

**SECTION 108
UNSAFE STRUCTURES AND EQUIPMENT**

[A] 108.1 General. When a structure or equipment is found by the code official to be unsafe, or when a structure is found unfit for human occupancy, or is found unlawful, such structure shall be condemned pursuant to the provisions of this code.

[A] 108.1.1 Unsafe structures. An unsafe structure is one that is found to be dangerous to the life, health, property or safety of the public or the occupants of the structure by not providing minimum safeguards to protect or warn occupants in the event of fire, or because such structure contains unsafe equipment or is so damaged, decayed, dilapidated, structurally unsafe or of such faulty construction or unstable foundation, that partial or complete col-lapse is possible.

SCOPE AND ADMINISTRATION

[A] 108.1.2 Unsafe equipment. Unsafe equipment includes any boiler, heating equipment, elevator, moving stairway, electrical wiring or device, flammable liquid containers or other equipment on the premises or within the structure which is in such disrepair or condition that such equipment is a hazard to life, health, property or safety of the public or occupants of the premises or structure.

[A] 108.1.3 Structure unfit for human occupancy. A structure is unfit for human occupancy whenever the code official finds that such structure is unsafe, unlawful or, because of the degree to which the structure is in disrepair or lacks maintenance, is insanitary, vermin or rat infested, contains filth and contamination, or lacks ventilation, illumination, sanitary or heating facilities or other essential equipment required by this code, or because the location of the structure constitutes a hazard to the occupants of the structure or to the public.

[A] 108.1.4 Unlawful structure. An unlawful structure is one found in whole or in part to be occupied by more persons than permitted under this code, or was erected, altered or occupied contrary to law.

[A] 108.1.5 Dangerous structure or premises. For the purpose of this code, any structure or premises that has any or all of the conditions or defects described below shall be considered dangerous:

1. Any door, aisle, passageway, stairway, exit or other means of egress that does not conform to the approved building or fire code of the jurisdiction as related to the requirements for existing buildings.
2. The walking surface of any aisle, passageway, stairway, exit or other means of egress is so warped, worn loose, torn or otherwise unsafe as to not provide safe and adequate means of egress.
3. Any portion of a building, structure or appurtenance that has been damaged by fire, earthquake, wind, flood, deterioration, neglect, abandonment, vandalism or by any other cause to such an extent that it is likely to partially or completely collapse, or to become detached or dislodged.
4. Any portion of a building, or any member, appurtenance or ornamentation on the exterior thereof that is not of sufficient strength or stability, or is not so anchored, attached or fastened in place so as to be capable of resisting natural or artificial loads of one and one-half the original designed value.
5. The building or structure, or part of the building or structure, because of dilapidation, deterioration, decay, faulty construction, the removal or movement of some portion of the ground necessary for the support, or for any other reason, is likely to partially or completely collapse, or some portion of the foundation or underpinning of the building or structure is likely to fail or give way.

6. The building or structure, or any portion thereof, is clearly unsafe for its use and occupancy.
7. The building or structure is neglected, damaged, dilapidated, unsecured or abandoned so as to become an attractive nuisance to children who might play in the building or structure to their danger, becomes a harbor for vagrants, criminals or immoral persons, or enables persons to resort to the building or structure for committing a nuisance or an unlawful act.
8. Any building or structure has been constructed, exists or is maintained in violation of any specific requirement or prohibition applicable to such building or structure provided by the approved building or fire code of the jurisdiction, or of any law or ordinance to such an extent as to present either a substantial risk of fire, building collapse or any other threat to life and safety.
9. A building or structure, used or intended to be used for dwelling purposes, because of inadequate maintenance, dilapidation, decay, damage, faulty construction or arrangement, inadequate light, ventilation, mechanical or plumbing system, or otherwise, is determined by the code official to be unsanitary, unfit for human habitation or in such a condition that is likely to cause sickness or dis-ease.
10. Any building or structure, because of a lack of sufficient or proper fire-resistance-rated construction, fire protection systems, electrical system, fuel connections, mechanical system, plumbing system or other cause, is determined by the code official to be a threat to life or health.
11. Any portion of a building remains on a site after the demolition or destruction of the building or structure or whenever any building or structure is abandoned so as to constitute such building or portion thereof as an attractive nuisance or hazard to the public.

[A] 108.2 Closing of vacant structures. If the structure is vacant and unfit for human habitation and occupancy, and is not in danger of structural collapse, the code official is authorized to post a placard of condemnation on the premises and order the structure closed up so as not to be an attractive nuisance. Upon failure of the owner to close up the premises within the time specified in the order, the code official shall cause the premises to be closed and secured through any available public agency or by contract or arrangement by private persons and the cost thereof shall be charged against the real estate upon which the structure is located and shall be a lien upon such real estate and may be collected by any other legal resource.

[A] 108.2.1 Authority to disconnect service utilities. The code official shall have the authority to authorize disconnection of utility service to the building, structure or system regulated by this code and the referenced codes and standards set forth in Section 102.7 in case of emergency where

necessary to eliminate an immediate hazard to life or property or when such utility connection has been made without approval. The code official shall notify the serving utility and, whenever possible, the owner and occupant of the building, structure or service system of the decision to disconnect prior to taking such action. If not notified prior to disconnection the owner or occupant of the building structure or service system shall be notified in writing as soon as practical thereafter.

[A] 108.3 Notice. Whenever the code official has condemned a structure or equipment under the provisions of this section, notice shall be posted in a conspicuous place in or about the structure affected by such notice and served on the owner or the person or persons responsible for the structure or equipment in accordance with Section 107.3. If the notice pertains to equipment, it shall also be placed on the condemned equipment. The notice shall be in the form prescribed in Section 107.2.

[A] 108.4 Placarding. Upon failure of the owner or person responsible to comply with the notice provisions within the time given, the code official shall post on the premises or on defective equipment a placard bearing the word "Condemned" and a statement of the penalties provided for occupying the premises, operating the equipment or removing the placard.

[A] 108.4.1 Placard removal. The code official shall remove the condemnation placard whenever the defect or defects upon which the condemnation and placarding action were based have been eliminated. Any person who defaces or removes a condemnation placard without the approval of the code official shall be subject to the penalties provided by this code.

[A] 108.5 Prohibited occupancy. Any occupied structure condemned and placarded by the code official shall be vacated as ordered by the code official. Any person who shall occupy a placarded premises or shall operate placarded equipment, and any owner or any person responsible for the premises who shall let anyone occupy a placarded premises or operate placarded equipment shall be liable for the penalties provided by this code.

[A] 108.6 Abatement methods. The owner, operator or occupant of a building, premises or equipment deemed unsafe by the code official shall abate or cause to be abated or corrected such unsafe conditions either by repair, rehabilitation, demolition or other approved corrective action.

[A] 108.7 Record. The code official shall cause a report to be filed on an unsafe condition. The report shall state the occupancy of the structure and the nature of the unsafe condition.

**SECTION 109
EMERGENCY MEASURES**

[A] 109.1 Imminent danger. When, in the opinion of the code official, there is imminent danger of failure or collapse of a building or structure which endangers life, or when any structure or part of a structure has fallen and life is endangered by the occupation of the structure, or when there is actual or potential danger to the building occupants or those in the proximity of any

structure because of explosives, explosive fumes or vapors or the presence of toxic fumes, gases or materials, or operation of defective or dangerous equipment, the code official is hereby authorized and empowered to order and require the occupants to vacate the premises forthwith. The code official shall cause to be posted at each entrance to such structure a notice reading as follows: "This Structure Is Unsafe and Its Occupancy Has Been Prohibited by the Code Official." It shall be unlawful for any person to enter such structure except for the purpose of securing the structure, making the required repairs, removing the hazardous condition or of demolishing the same.

[A] 109.2 Temporary safeguards. Notwithstanding other provisions of this code, whenever, in the opinion of the code official, there is imminent danger due to an unsafe condition, the code official shall order the necessary work to be done, including the boarding up of openings, to render such structure temporarily safe whether or not the legal procedure herein described has been instituted; and shall cause such other action to be taken as the code official deems necessary to meet such emergency.

[A] 109.3 Closing streets. When necessary for public safety, the code official shall temporarily close structures and close, or order the authority having jurisdiction to close, sidewalks, streets, public ways and places adjacent to unsafe structures, and prohibit the same from being utilized.

[A] 109.4 Emergency repairs. For the purposes of this section, the code official shall employ the necessary labor and materials to perform the required work as expeditiously as possible.

[A] 109.5 Costs of emergency repairs. *Costs incurred in the performance of emergency work shall be paid by the city. The cost of the emergency repairs, including reasonable administrative costs, shall be billed to the property, and if not paid, shall be assessed and levied on the property upon which emergency repairs were made and shall constitute a lien upon such property. This assessment shall be collected at the same time and in the same manner as are the regular city taxes, if unpaid, and shall be subject to the same penalties as are levied for unpaid property taxes.*

[A] 109.6 Hearing. Any person ordered to take emergency measures shall comply with such order forthwith. Any affected person shall thereafter, upon petition directed to the appeals board, be afforded a hearing as described in this code.

**SECTION 110
DEMOLITION**

[A] 110.1 General. The code official shall order the owner of any premises upon which is located any structure, which in the code official judgment after review is so deteriorated or dilapidated or has become so out of repair as to be dangerous, unsafe, insanitary or otherwise unfit for human habitation or occupancy, and such that it is unreasonable to repair the structure, to demolish and remove such structure; or if such structure is capable of being made safe by repairs, to repair and make safe and sanitary, or to board up and hold for future repair or to demolish and remove at

SCOPE AND ADMINISTRATION

the owner 's option; or where there has been a cessation of normal construction of any structure for a period of more than two years, the code official shall order the owner to demolish and remove such structure, or board up until future repair. Boarding the building up for future repair shall not extend beyond one year, unless approved by the building official.

[A] **110.2 Notices and orders.** All notices and orders shall comply with Section 107.

[A] **110.3 Failure to comply.** If the owner of a premises fails to comply with a demolition order within the time prescribed, the code official shall cause the structure to be demolished and removed, either through an available public agency or by contract or arrangement with private persons, and the cost of such demolition and removal shall be charged against the real estate upon which the structure is located and shall be a lien upon such real estate.

[A] **110.4 Salvage materials.** When any structure has been ordered demolished and removed, the governing body or other designated officer under said contract or arrangement aforesaid shall have the right to sell the salvage and valuable materials at the highest price obtainable. The net proceeds of such sale, after deducting the expenses of such demolition and removal, shall be promptly remitted with a report of such sale or transaction, including the items of expense and the amounts deducted, for the person who is entitled thereto, subject to any order of a court. If such a surplus does not remain to be turned over, the report shall so state.

SECTION 111 MEANS OF APPEAL

[A] **111.1 Application for appeal.** Any person directly affected by a decision of the code official or a notice or order issued under this code shall have the right to appeal to the board of appeals, provided that a written application for appeal is filed within 20 days after the day the decision, notice or order was served. An application for appeal shall be based on a claim that the true intent of this code or the rules legally adopted thereunder have been incorrectly interpreted, the provisions of this code do not fully apply, or the requirements of this code are adequately satisfied by other means.

[A] **111.2 Membership of board.** The board of appeals shall consist of a minimum of three members who are qualified by experience and training to pass on matters pertaining to property maintenance and who are not employees of the jurisdiction. The code official shall be an ex-officio member but shall have no vote on any matter before the board. The board shall be appointed by the chief appointing authority, and shall serve staggered and overlapping terms.

[A] **111.2.1 Alternate members.** The chief appointing authority shall appoint a minimum of two alternate members who shall be called by the board chairman to hear appeals during the absence or disqualification of a member. Alternate members shall possess the qualifications required for board membership.

[A] **111.2.2 Chairman.** The board shall annually select one of its members to serve as chairman.

[A] **111.2.3 Disqualification of member.** A member shall not hear an appeal in which that member has a personal, professional or financial interest.

[A] **111.2.4 Secretary.** The chief administrative officer shall designate a qualified person to serve as secretary to the board. The secretary shall file a detailed record of all proceedings in the office of the chief administrative officer.

[A] **111.2.5 Compensation of members.** Compensation of members shall be determined by law.

[A] **111.3 Notice of meeting.** The board shall meet upon notice from the chairman, within 20 days of the filing of an appeal, or at stated periodic meetings.

[A] **111.4 Open hearing.** All hearings before the board shall be open to the public. The appellant, the appellant's representative, the code official and any person whose interests are affected shall be given an opportunity to be heard. A quorum shall consist of a minimum of two-thirds of the board membership.

[A] **111.4.1 Procedure.** The board shall adopt and make available to the public through the secretary procedures under which a hearing will be conducted. The procedures shall not require compliance with strict rules of evidence, but shall mandate that only relevant information be received.

[A] **111.5 Postponed hearing.** When the full board is not present to hear an appeal, either the appellant or the appellant's representative shall have the right to request a postponement of the hearing.

[A] **111.6 Board decision.** The board shall modify or reverse the decision of the code official only by a concurring vote of a majority of the total number of appointed board members.

[A] **111.6.1 Records and copies.** The decision of the board shall be recorded. Copies shall be furnished to the appellant and to the code official.

[A] **111.6.2 Administration.** The code official shall take immediate action in accordance with the decision of the board.

[A] **111.7 Court review.** Any person, whether or not a previous party of the appeal, shall have the right to apply to the appropriate court for a writ of certiorari to correct errors of law. Application for review shall be made in the manner and time required by law following the filing of the decision in the office of the chief administrative officer.

[A] **111.8 Stays of enforcement.** Appeals of notice and orders (other than Imminent Danger notices) shall stay the enforcement of the notice and order until the appeal is heard by the appeals board.

**SECTION 112
STOP WORK ORDER**

[A] **112.1 Authority.** Whenever the code official finds any work regulated by this code being performed in a manner contrary to the provisions of this code or in a dangerous or unsafe manner, the code official is authorized to issue a stop work order.

[A] **112.2 Issuance.** A stop work order shall be in writing and shall be given to the owner of the property, to the owner's agent, or to the person doing the work. Upon issuance of a stop work order, the cited work shall immediately cease. The stop work order shall state the reason for the order and the conditions under which the cited work is authorized to resume.

[A] **112.3 Emergencies.** Where an emergency exists, the code official shall not be required to give a written notice prior to stopping the work.

[A] **112.4 Failure to comply.** Any person who shall continue any work after having been served with a stop work order, except such work as that person is directed to perform to remove a violation or unsafe condition, shall be liable to a fine of not less than [AMOUNT) dollars or more than [AMOUNT) dollars.

CHAPTER 2

DEFINITIONS

SECTION 201 GENERAL

201.1 Scope. Unless otherwise expressly stated, the following terms shall, for the purposes of this code, have the meanings shown in this chapter.

201.2 Interchangeability. Words stated in the present tense include the future; words stated in the masculine gender include the feminine and neuter; the singular number includes the plural and the plural, the singular.

201.3 Terms defined in other codes. Where terms are not defined in this code and are defined in the International Building Code, International Existing Building Code, International Fire Code, International Fuel Gas Code, International Mechanical Code, International Plumbing Code, International Residential Code, International Zoning Code or NFPA 70, such terms shall have the meanings ascribed to them as stated in those codes.

201.4 Terms not defined. Where terms are not defined through the methods authorized by this section, such terms shall have ordinarily accepted meanings such as the context implies.

201.5 Parts. Whenever the words "dwelling unit," "dwelling," "premises," "building," "rooming house," "rooming unit," "housekeeping unit" or "story" are stated in this code, they shall be construed as though they were followed by the words "or any part thereof."

SECTION 202 GENERAL DEFINITIONS

ANCHORED. Secured in a manner that provides positive connection.

[A] APPROVED. Approved by the code official.

BASEMENT. That portion of a building which is partly or completely below grade.

BATHROOM. A room containing plumbing fixtures including a bathtub or shower.

BEDROOM. Any room or space used or intended to be used for sleeping purposes in either a dwelling or sleeping unit.

BRUSH means *tree trimmings/branches less than eight inches in diameter and eight feet in length.*

[A] CODE OFFICIAL. The official who is charged with the administration and enforcement of this code, or any duly authorized representative.

CONDEMN. To adjudge unfit for occupancy.

DETACHED. When a structural element is physically disconnected from another and that connection is necessary to provide a positive connection.

DETERIORATION. To weaken, disintegrate, corrode, rust or decay and lose effectiveness.

[B] DWELLING UNIT. A single unit providing complete, independent living facilities for one or more persons, including permanent provisions for living, sleeping, eating, cooking and sanitation.

[Z] EASEMENT. That portion of land or property reserved for present or future use by a person or agency other than the legal fee owner(s) of the property. The easement shall be permitted to be for use under, on or above a said lot or lots.

EQUIPMENT SUPPORT. Those structural members or assemblies of members or manufactured elements, including braces, frames, lugs, snuggers, hangers or saddles, that transmit gravity load, lateral load and operating load between the equipment and the structure.

EXTERIOR PROPERTY. The open space on the premises and on adjoining property under the control of owners or operators of such premises.

[B] GUARD. A building component or a system of building components located at or near the open sides of elevated walking surfaces that minimizes the possibility of a fall from the walking surface to a lower level.

[B] HABITABLE SPACE. Space in a structure for living, sleeping, eating or cooking. Bathrooms, toilet rooms, closets, halls, storage or utility spaces, and similar areas are not considered habitable spaces.

HOUSEKEEPING UNIT. A room or group of rooms forming a single habitable space equipped and intended to be used for living, sleeping, cooking and eating which does not contain, within such a unit, a toilet, lavatory and bathtub or shower.

IMMINENT DANGER. A condition which could cause serious or life-threatening injury or death at any time.

INFESTATION. The presence, within or contiguous to, a structure or premises of insects, rats, vermin or other pests.

INOPERABLE MOTOR VEHICLE. A vehicle which cannot be driven upon the public streets for reason including but not limited to being unlicensed, wrecked, abandoned, in a state of disrepair, or incapable of being moved under its own power.

[A] LABELED. Equipment, materials or products to which have been affixed a label, seal, symbol or other identifying mark of a nationally recognized testing laboratory, inspection agency or other organization concerned with product evaluation that maintains periodic inspection of the production of the above-labeled items and whose labeling indicates either that the equipment, material or product meets identified standards or has been tested and found suitable for a specified purpose.

LET FOR OCCUPANCY or LET. To permit, provide or offer possession or occupancy of a dwelling, dwelling unit, rooming unit, building, premise or structure by a person who is or is not the legal owner of record thereof, pursuant to a written or unwritten lease, agreement or license, or pursuant to a recorded or unrecorded agreement of contract for the sale of land.

NEGLECT. The lack of proper maintenance for a building or structure.

[A] OCCUPANCY. The purpose for which a building or portion thereof is utilized or occupied.

OCCUPANT. Any individual living or sleeping in a building, or having possession of a space within a building.

OPENABLE AREA. That part of a window, skylight or door which is available for unobstructed ventilation and which opens directly to the outdoors.

OPERATOR. Any person who has charge, care or control of a structure or premises which is let or offered for occupancy.

[A] OWNER. Any person, agent, operator, firm or corporation having a legal or equitable interest in the property; or recorded in the official records of the state, county or municipality as holding title to the property; or otherwise having control of the property, including the guardian of the estate of any such person, and the executor or administrator of the estate of such person if ordered to take possession of real property by a court.

PERSON. An individual, corporation, partnership or any other group acting as a unit.

PEST ELIMINATION. The control and elimination of insects, rodents or other pests by eliminating their harborage places; by removing or making inaccessible materials that serve as their food or water; by other approved pest elimination methods.

[A] PREMISES. A lot, plot or parcel of land, easement or public way. Including any structures thereon.

[A] PUBLIC WAY. Any street, alley or similar parcel of land essentially unobstructed from the ground to the sky, which is deeded, dedicated or otherwise permanently appropriated to the public for public use.

ROOMING HOUSE. A building arranged or occupied for lodging, with or without meals, for compensation and not occupied as a one- or two-family dwelling.

ROOMING UNIT. Any room or group of rooms forming a single habitable unit occupied or intended to be occupied for sleeping or living, but not for cooking purposes.

[B] SLEEPING UNIT. A room or space in which people - sleep, which can also include permanent provisions for living, eating and either sanitation or kitchen facilities, but not both. Such rooms and spaces that are also part of a dwelling unit are not sleeping units.

SOLID WASTE *shall refer to and mean normally solid or semi-solid materials that are useless or unwanted resulting from human activities and include garbage (decomposable wastes from food) and rubbish (non-decomposable wastes, either combustible [such as paper, wood and cloth] or noncombustible [such as metal, glass and ceramics]) but shall not include dead animals and human or animal excrement or yard rubbish or diapers containing fecal material other than the residue remaining after being emptied.*

STRICT LIABILITY OFFENSE. An offense in which the prosecution in a legal proceeding is not required to prove criminal intent as a part of its case. It is enough to prove that the defendant either did an act which was prohibited, or failed to do an act which the defendant was legally required to do.

[A] STRUCTURE. That which is built or constructed or a portion thereof.

TENANT. A person, corporation, partnership or group, whether or not the legal owner of record, occupying a building or portion thereof as a unit.

TOILET ROOM. A room containing a water closet or urinal but not a bathtub or shower.

ULTIMATE DEFORMATION. The deformation at which failure occurs and which shall be deemed to occur if the sustainable load reduces to 80 percent or less of the maximum strength.

[M] VENTILATION. The natural or mechanical process of supplying conditioned or unconditioned air to, or removing such air from, any space.

WORKMANLIKE. Executed in a skilled manner; e.g., generally plumb, level, square, in line, undamaged and without marring adjacent work.

YARD RUBBISH *means grass clippings, branches, twigs, leaves, weeds, shrub clippings and general yard and garden waste materials.*

[Z] YARD. An open space on the same lot with a structure.

CHAPTER 3

GENERAL REQUIREMENTS

SECTION 301 GENERAL

301.1 Scope. The provisions of this chapter shall govern the minimum conditions and the responsibilities of persons for maintenance of structures, equipment and exterior property.

301.2 Responsibility. The owner of the premises shall maintain the structures and exterior property in compliance with these requirements, except as otherwise provided for in this code. A person shall not occupy as owner-occupant or permit another person to occupy premises which are not in a sanitary and safe condition and which do not comply with the requirements of this chapter. Occupants of a dwelling unit, rooming unit or housekeeping unit are responsible for keeping in a clean, sanitary and safe condition that part of the dwelling unit, rooming unit, housekeeping unit or premises which they occupy and control.

301.3 Vacant structures and land. All vacant structures and premises thereof or vacant land shall be maintained in a clean, safe, secure and sanitary condition as provided herein so as not to cause a blighting problem or adversely affect the public health or safety.

SECTION 302 EXTERIOR PROPERTY AREAS

302.1 Sanitation. All exterior property and premises shall be maintained in a clean, safe and sanitary condition. The occupant shall keep that part of the exterior property which such occupant occupies or controls in a clean and sanitary condition.

302.2 Grading and drainage. All premises shall be graded and maintained to prevent the erosion of soil and to prevent the accumulation of stagnant water thereon, or within any structure located thereon.

Exception: Approved retention areas and reservoirs.

302.3 Sidewalks and driveways. All sidewalks, walkways, stairs, driveways, parking spaces and similar areas shall be kept in a proper state of repair, and maintained free from hazardous conditions.

302.4 Weeds. *The provisions of Sections 14.142, 14.143 and 14.144 of the Code of Ordinances of the City of Hillsdale are incorporated herein in their entirety and made a part of this section by reference. All premises and exterior property shall be maintained free from weeds or plant growth in excess of ten (10) inches in height. "Weeds" is defined as including all grasses, annual plants and other vegetation considered as harmful to inhabitants, animals or the environment. "Plant growth" is defined as including all plants other than weeds, trees and shrubs, flowers or cultivated plants in gardens.*

302.4.1. *Upon the failure of the owner, grantee, transferee, mortgagee, lessee or agent having charge of the property to cut and destroy weeds or plant growth after service of a notice of violation, such person or entity shall be subject to prosecution in accordance in with sections 106, 106.1, and 106.2 and as otherwise provided by ordinance.*

302.4.2. *Upon the failure of the owner, grantee, transferee, mortgagee, lessee, agent or occupant having charge of the property to cut and destroy weeds or plant growth after receiving notice of violation, any duly authorized city employee or contractor is, after notice to such person or entity, authorized to enter upon the property in violation and cut, destroy and remove the weeds and plant growth growing thereon.*

302.4.3. *The costs of cutting, destroying, and removing weeds and plant growth from the property in violation shall be paid by the owner, grantee, transferee, mortgagee, lessee, agent or occupant having charge of the property and shall be assessed and levied upon the property upon which the violation was located if not paid within thirty (30) days of the date they are charged or billed to the property owner. All such penalties and costs shall constitute a lien upon the property and shall be collected at the same time and in the same manner as are regular city taxes, and shall be subject to the same penalties as are levied for unpaid property taxes.*

302.5 Rodent harborage. All structures and exterior property shall be kept free from rodent harborage and infestation. Where rodents are found, they shall be promptly exterminated by approved processes which will not be injurious to human health. After pest elimination, proper precautions shall be taken to eliminate rodent harborage and prevent re-infestation.

302.6 Exhaust vents. Pipes, ducts, conductors, fans or blowers shall not discharge gases, steam, vapor, hot air, grease, smoke, odors or other gaseous or particulate wastes directly upon abutting or adjacent public or private property or that of another tenant.

302.7 Accessory structures. All accessory structures, including detached garages, fences and walls, shall be maintained structurally sound and in good repair.

302.8 Motor vehicles. *Subject to the provisions of this code and except as provided and authorized under other applicable statutes, ordinances and regulations no inoperative or unlicensed motor vehicle shall be parked, kept or stored on any premises unless completely enclosed within a garage or similar enclosed area designed and approved for such purpose.*

302.8.1 Maintenance or repair of motor vehicles. *Subject to the provisions of this code and except as provided and authorized under other applicable statutes, ordinances and regulations no motor vehicle, whether inoperative or operative, licensed or*

unlicensed, shall be parked, kept or stored on any premises in a state of major disassembly, disrepair or while in the process of being stripped or dismantled, whether in connection with body work, rebuilding, restoration or otherwise unless all of such work is performed inside a completely enclosed garage or similar enclosed structure designed and approved for such purpose.

302.9 Defacement of property. No person shall willfully or wantonly damage, mutilate or deface any exterior surface of any structure or building on any private or public property by placing thereon any marking, carving or graffiti.

It shall be the responsibility of the owner to restore said surface to an approved state of maintenance and repair.

SECTION 303 SWIMMING POOLS, SPAS AND HOT TUBS

303.1 Swimming pools. Swimming pools shall be maintained in a clean and sanitary condition, and in good repair.

303.2 Enclosures. Private swimming pools, hot tubs and spas, containing water more than 24 inches (610 mm) in depth shall be completely surrounded by a fence or barrier at least 48 inches (1219 mm) in height above the finished ground level measured on the side of the barrier away from the pool. Gates and doors in such barriers shall be self-closing and self-latching. Where the self-latching device is a minimum of 54 inches (1372 mm) above the bottom of the gate, the release mechanism shall be located on the pool side of the gate. Self-closing and self-latching gates shall be maintained such that the gate will positively close and latch when released from an open position of 6 inches (152 mm) from the gatepost. No existing pool enclosure shall be removed, replaced or changed in a manner that reduces its effectiveness as a safety barrier.

Exception: Spas or hot tubs with a safety cover that complies with ASTM F 1346 shall be exempt from the provisions of this section.

SECTION 304 EXTERIOR STRUCTURE

304.1 General. The exterior of a structure shall be maintained in good repair, structurally sound and sanitary so as not to pose a threat to the public health, safety or welfare.

304.1.1 Unsafe conditions. The following conditions shall be determined as unsafe and shall be repaired or replaced to comply with the International Building Code or the International Existing Building Code as required for existing buildings:

1. The nominal strength of any structural member is exceeded by nominal loads, the load effects or the required strength;

2. The anchorage of the floor or roof to walls or columns, and of walls and columns to foundations is not capable of resisting all nominal loads or load effects;
3. Structures or components thereof that have reached their limit state;
4. Siding and masonry joints including joints between the building envelope and the perimeter of windows, doors and skylights are not maintained, weather resistant or water tight;
5. Structural members that have evidence of deterioration or that are not capable of safely supporting all nominal loads and load effects;
6. Foundation systems that are not firmly supported by footings, are not plumb and free from open cracks and breaks, are not properly anchored or are not capable of supporting all nominal loads and resisting all load effects;
7. Exterior walls that are not anchored to supporting and supported elements or are not plumb and free of holes, cracks or breaks and loose or rotting materials, are not properly anchored or are not capable of supporting all nominal loads and resisting all load effects;
8. Roofing or roofing components that have defects that admit rain, roof surfaces with inadequate drainage, or any portion of the roof framing that is not in good repair with signs of deterioration, fatigue or without proper anchorage and incapable of supporting all nominal loads and resisting all load effects;
9. Flooring and flooring components with defects that affect serviceability or flooring components that show signs of deterioration or fatigue, are not properly anchored or are incapable of supporting all nominal loads and resisting all load effects;
10. Veneer, cornices, belt courses, corbels, trim, wall facings and similar decorative features not properly anchored or that are anchored with connections not capable of supporting all nominal loads and resisting all load effects;
11. Overhang extensions or projections including, but not limited to, trash chutes, canopies, marquees, signs, awnings, fire escapes, standpipes and exhaust ducts not properly anchored or that are anchored with connections not capable of supporting all nominal loads and resisting all load effects;
12. Exterior stairs, decks, porches, balconies and all similar appurtenances attached thereto, including guards and handrails, are not structurally sound, not properly anchored or that are anchored with

LIGHT, VENTILATION AND OCCUPANCY LIMITATIONS

connections not capable of supporting all nominal loads and resisting all load effects; or

13. Chimneys, cooling towers, smokestacks and similar appurtenances not structurally sound or not properly anchored, or that are anchored with connections not capable of supporting all nominal loads and resisting all load effects.

Exceptions:

1. When substantiated otherwise by an approved method.
2. Demolition of unsafe conditions shall be permitted when approved by the code official.

304.2 Protective treatment. All exterior surfaces, including but not limited to, doors, door and window frames, cornices, porches, trim, balconies, decks and fences, shall be maintained in good condition. Exterior wood surfaces, other than decay-resistant woods, shall be protected from the elements and decay by painting or other protective covering or treatment. Peeling, flaking and chipped paint shall be eliminated and surfaces repainted. All siding and masonry joints, as well as those between the building envelope and the perimeter of windows, doors and skylights, shall be maintained weather resistant and water tight. All metal surfaces subject to rust or corrosion shall be coated to inhibit such rust and corrosion, and all surfaces with rust or corrosion shall be stabilized and coated to inhibit future rust and corrosion. Oxidation stains shall be removed from exterior surfaces. Surfaces designed for stabilization by oxidation are exempt from this requirement.

[F] 304.3 Premises identification. Buildings shall have approved address numbers placed in a position to be plainly legible and visible from the street or road fronting the property. These numbers shall contrast with their background. Address numbers shall be Arabic numerals or alphabet letters. Numbers shall be a minimum of 4 inches (102 mm) in height with a minimum stroke width of 0.5 inch (12.7 mm).

304.4 Structural members. All structural members shall be maintained free from deterioration, and shall be capable of safely supporting the imposed dead and live loads.

304.5 Foundation walls. All foundation walls shall be maintained plumb and free from open cracks and breaks and shall be kept in such condition so as to prevent the entry of rodents and other pests.

304.6 Exterior walls. All exterior walls shall be free from holes, breaks, and loose or rotting materials; and maintained weatherproof and properly surface coated where required to prevent deterioration.

304.7 Roofs and drainage. The roof and flashing shall be sound, tight and not have defects that admit rain. Roof drainage shall be adequate to prevent dampness or deterioration in the walls or interior portion of the structure. Roof drains, gutters and

downspouts shall be maintained in good repair and free from obstructions. Roof water shall not be discharged in a manner that creates a public nuisance.

304.8 Decorative features. All cornices, belt courses, corbels, terra cotta trim, wall facings and similar decorative features shall be maintained in good repair with proper anchorage and in a safe condition.

304.9 Overhang extensions. All overhang extensions including, but not limited to canopies, marquees, signs, metal awnings, fire escapes, standpipes and exhaust ducts shall be maintained in good repair and be properly anchored so as to be kept in a sound condition. When required, all exposed surfaces of metal or wood shall be protected from the elements and against decay or rust by periodic application of weather-coating materials, such as paint or similar surface treatment.

304.10 Stairways, decks, porches and balconies. Every exterior stairway, deck, porch and balcony, and all appurtenances attached thereto, shall be maintained structurally sound, in good repair, with proper anchorage and capable of supporting the imposed loads.

304.11 Chimneys and towers. All chimneys, cooling towers, smoke stacks, and similar appurtenances shall be maintained structurally safe and sound, and in good repair. All exposed surfaces of metal or wood shall be protected from the elements and against decay or rust by periodic application of weather-coating materials, such as paint or similar surface treatment.

304.12 Handrails and guards. Every handrail and guard shall be firmly fastened and capable of supporting normally imposed loads and shall be maintained in good condition.

304.13 Window, skylight and door frames. Every window, skylight, door and frame shall be kept in sound condition, good repair and weather tight.

304.13.1 Glazing. All glazing materials shall be maintained free from cracks and holes.

304.13.2 Openable windows. Every window, other than a fixed window, shall be easily openable and capable of being held in position by window hardware.

304.14 Insect screens. *During the period from April 15 to December 1, every door, window and other outside opening utilized or required for ventilation purposes serving any structure containing habitable rooms, food preparation areas, food service areas or any areas where products to be included or utilized in food for human consumption are processed, manufactured, packaged or stored shall be supplied with approved tightly fitting screens of not less than 16 mesh per inch and every swinging door shall have a self-closing device in good working condition.*

Exception: Screens shall not be required where other approved means, such as air curtains or insect repellent fans, are employed.

SECTION 305 INTERIOR STRUCTURE

304.15 Doors. All exterior doors, door assemblies, operator systems if provided, and hardware shall be maintained in good condition. Locks at all entrances to dwelling units and sleeping units shall tightly secure the door. Locks on means of egress doors shall be in accordance with Section 702.3.

304.16 Basement hatchways. Every basement hatchway shall be maintained to prevent the entrance of rodents, rain and surface drainage water.

304.17 Guards for basement windows. Every basement window that is openable shall be supplied with rodent shields, storm windows or other approved protection against the entry of rodents.

304.18 Building security. Doors, windows or hatchways for dwelling units, room units or housekeeping units shall be provided with devices designed to provide security for the occupants and property within.

304.18.1 Doors. Doors providing access to a dwelling unit, rooming unit or housekeeping unit that is rented, leased or let shall be equipped with a deadbolt lock designed to be readily openable from the side from which egress is to be made without the need for keys, special knowledge or effort and shall have a minimum lock throw of 1 inch (25 mm). Such deadbolt locks shall be installed according to the manufacturer's specifications and maintained in good working order. For the purpose of this section, a sliding bolt shall not be considered an acceptable deadbolt lock.

304.18.2 Windows. Operable windows located in whole or in part within 6 feet (1828 mm) above ground level or a walking surface below that provide access to a dwelling unit, rooming unit or housekeeping unit that is rented, leased or let shall be equipped with a window sash locking device.

304.18.3 Basement hatchways. Basement hatchways that provide access to a dwelling unit, rooming unit or housekeeping unit that is rented, leased or let shall be equipped with devices that secure the units from unauthorized entry.

304.19 Outdoor furniture. *All outdoor furniture will be constructed of materials that are made to withstand outdoor weather conditions, to prevent dampness or deterioration of said furniture. All exposed surfaces shall be protected from the elements and against decay or rust by periodic application of weather coating materials, such as paint or similar surface treatment*

304.20 Gates. All exterior gates, gate assemblies, operator systems if provided, and hardware shall be maintained in good condition. Latches at all entrances shall tightly secure the gates.

General. The interior of a structure and equipment therein shall be maintained in good repair, structurally sound and in a sanitary condition. Occupants shall keep that part of the structure which they occupy or control in a clean and sanitary condition. Every owner of a structure containing a rooming house, housekeeping units, a hotel, a dormitory, two or more dwelling units or two or more nonresidential occupancies, shall maintain, in a clean and sanitary condition, the shared or public areas of the structure and exterior property.

305.1.1 Unsafe conditions. The following conditions shall be determined as unsafe and shall be repaired or replaced to comply with the International Building Code or the International Existing Building Code as required for existing buildings:

1. The nominal strength of any structural member is exceeded by nominal loads, the load effects or the required strength;
2. The anchorage of the floor or roof to walls or columns, and of walls and columns to foundations is not capable of resisting all nominal loads or load effects;
3. Structures or components thereof that have reached their limit state;
4. Structural members are incapable of supporting nominal loads and load effects;
5. Stairs, landings, balconies and all similar walking surfaces, including guards and handrails, are not structurally sound, not properly anchored or are anchored with connections not capable of supporting all nominal loads and resisting all load effects;
6. Foundation systems that are not firmly supported by footings are not plumb and free from open cracks and breaks, are not properly anchored or are not capable of supporting all nominal loads and resisting all load effects.

Exceptions:

1. When substantiated otherwise by an approved method.
2. Demolition of unsafe conditions shall be permitted when approved by the code official.

305.2 Structural members. All structural members shall be maintained structurally sound, and be capable of supporting the imposed loads.

305.3 Interior surfaces. All interior surfaces, including windows and doors, shall be maintained in good, clean and sanitary condition. Peeling, chipping, flaking or abraded paint shall be repaired, removed or covered. Cracked or loose plaster, decayed wood and other defective surface conditions shall be corrected.

LIGHT, VENTILATION AND OCCUPANCY LIMITATIONS

305.4 Stairs and walking surfaces. Every stair, ramp, landing, balcony, porch, deck or other walking surface shall be maintained in sound condition and good repair.

305.5 Handrails and guards. Every handrail and guard shall be firmly fastened and capable of supporting normally imposed loads and shall be maintained in good condition.

305.6 Interior doors. Every interior door shall fit reasonably well within its frame and shall be capable of being opened and closed by being properly and securely attached to jambs, headers or tracks as intended by the manufacturer of the attachment hardware.

SECTION 306 COMPONENT SERVICEABILITY

306.1 General. The components of a structure and equipment therein shall be maintained in good repair, structurally sound and in a sanitary condition.

306.1.1 Unsafe conditions. Where any of the following conditions cause the component or system to be beyond its limit state, the component or system shall be determined as unsafe and shall be repaired or replaced to comply with the International Building Code or the International Existing Building Code as required for existing buildings:

1. Soils that have been subjected to any of the following conditions:
 - 1.1. Collapse of footing or foundation system;
 - 1.2. Damage to footing, foundation, concrete or other structural element due to soil expansion;
 - 1.3. Adverse effects to the design strength of footing, foundation, concrete or other structural element due to a chemical reaction from the soil;
 - 1.4. Inadequate soil as determined by a geotechnical investigation;
 - 1.5. Where the allowable bearing capacity of the soil is in doubt; or
 - 1.6. Adverse effects to the footing, foundation, concrete or other structural element due to the ground water table.
2. Concrete that has been subjected to any of the following conditions:
 - 2.1. Deterioration;
 - 2.2. Ultimate deformation;
 - 2.3. Fractures;

- 2.4. Fissures;
- 2.5. Spalling;
- 2.6. Exposed reinforcement; or
- 2.7. Detached, dislodged or failing connections.

3. Aluminum that has been subjected to any of the following conditions:

- 3.1. Deterioration;
- 3.2. Corrosion;
- 3.3. Elastic deformation;
- 3.4. Ultimate deformation;
- 3.5. Stress or strain cracks;
- 3.6. Joint fatigue; or
- 3.7. Detached, dislodged or failing connections.

4. Masonry that has been subjected to any of the following conditions:

- 4.1. Deterioration;
- 4.2. Ultimate deformation;
- 4.3. Fractures in masonry or mortar joints;
- 4.4. Fissures in masonry or mortar joints;
- 4.5. Spalling;
- 4.6. Exposed reinforcement; or
- 4.7. Detached, dislodged or failing connections.

5. Steel that has been subjected to any of the following conditions:

- 5.1. Deterioration;
- 5.2. Elastic deformation;
- 5.3. Ultimate deformation;
- 5.4. Metal fatigue; or
- 5.5. Detached, dislodged or failing connections.

6. Wood that has been subjected to any of the following conditions:

- 6.1. Ultimate deformation;

- 6.2. Deterioration;
- 6.3. Damage from insects, rodents and other vermin;
- 6.4. Fire damage beyond charring;
- 6.5. Significant splits and checks;
- 6.6. Horizontal shear cracks;
- 6.7. Vertical shear cracks;
- 6.8. Inadequate support;
- 6.9. Detached, dislodged or failing connections; or
- 6.10. Excessive cutting and notching.

Exceptions:

- 1. When substantiated otherwise by approved method.
- 2. Demolition of unsafe conditions shall be permitted when approved by the code official.

**SECTION 307
HANDRAILS AND GUARDRAILS**

307.1 General. Every exterior and interior flight of stairs having more than four risers shall have a handrail on one side of the stair and every open portion of a stair, landing, balcony, porch, deck, ramp or other walking surface which is more than 30 inches (762 mm) above the floor or grade below shall have guards. Handrails shall not be less than 30 inches (762 mm) in height or more than 42 inches (1067 mm) in height measured vertically above the nosing of the tread or above the finished floor of the landing or walking surfaces. Guards shall not be less than 30 inches (762 mm) in height above the floor of the landing, balcony, porch, deck, or ramp or other walking surface.

Exception: Guards shall not be required where exempted by the adopted building code.

**SECTION 308
SOLID WASTE**

308.1 Accumulation of solid waste. *Accumulation of solid waste. All exterior property and premises, and the interior of every structure, shall be free from any accumulation of solid waste.*

308.2 Refrigerators. *Refrigerators and similar equipment not in operation shall not be discarded, abandoned or stored on premises without first removing the doors*

**SECTION 309
PEST ELIMINATION**

309.1 Infestation. All structures shall be kept free from insect and rodent infestation. All structures in which insects or rodents are found shall be promptly exterminated by approved processes that will not be injurious to human health. After pest elimination, proper precautions shall be taken to prevent re-infestation.

309.2 Owner. The owner of any structure shall be responsible for pest elimination within the structure prior to renting or leasing the structure.

309.3 Single occupant. The occupant of a one-family dwelling or of a single-tenant nonresidential structure shall be responsible for pest elimination on the premises.

309.4 Multiple occupancy. The owner of a structure containing two or more dwelling units, a multiple occupancy, a rooming house or a nonresidential structure shall be responsible for pest elimination in the public or shared areas of the structure and exterior property. If infestation is caused by failure of an occupant to prevent such infestation in the area occupied, the occupant and owner shall be responsible for pest elimination.

309.5 Occupant. The occupant of any structure shall be responsible for the continued rodent and pest-free condition of the structure.

Exception: Where the infestations are caused by defects in the structure, the owner shall be responsible for pest elimination.

CHAPTER 4

LIGHT, VENTILATION AND OCCUPANCY LIMITATIONS

SECTION 401 GENERAL

401.1 Scope. The provisions of this chapter shall govern the minimum conditions and standards for light, ventilation and space for occupying a structure.

401.2 Responsibility. The owner of the structure shall provide and maintain light, ventilation and space conditions in compliance with these requirements. A person shall not occupy as owner-occupant, or permit another person to occupy, any premises that do not comply with the requirements of this chapter.

401.3 Alternative devices. In lieu of the means for natural light and ventilation herein prescribed, artificial light or mechanical ventilation complying with the International Building Code shall be permitted.

SECTION 402 LIGHT

402.1 Habitable spaces. Every habitable space shall have at least one window of approved size facing directly to the outdoors or to a court. The minimum total glazed area for every habitable space shall be 8 percent of the floor area of such room. Wherever walls or other portions of a structure face a window of any room and such obstructions are located less than 3 feet (914 mm) from the window and extend to a level above that of the ceiling of the room, such window shall not be deemed to face directly to the outdoors nor to a court and shall not be included as contributing to the required minimum total window area for the room.

Exception: Where natural light for rooms or spaces without exterior glazing areas is provided through an adjoining room, the unobstructed opening to the adjoining room shall be at least 8 percent of the floor area of the interior room or space, but a minimum of 25 square feet (2.33 m). The exterior glazing area shall be based on the total floor area being served.

402.2 Common halls and stairways. Every common hall and stairway in residential occupancies, other than in one- and two-family dwellings, shall be lighted at all times with at least a 60-watt standard incandescent light bulb for each 200 square feet (19 m of floor area or equivalent illumination, provided that the spacing between lights shall not be greater than 30 feet (9144 mm). In other than residential occupancies, means of egress, including exterior means of egress, stairways shall be illuminated at all times the building space served by the means of egress is occupied with a minimum of 1 foot-candle (11 lux) at floors, landings and treads.

402.3 Other spaces. All other spaces shall be provided with natural or artificial light sufficient to permit the maintenance of

sanitary conditions, and the safe occupancy of the space and utilization of the appliances, equipment and fixtures.

SECTION 403 VENTILATION

403.1 Habitable spaces. Every habitable space shall have at least one openable window. The total openable area of the window in every room shall be equal to at least 45 percent of the minimum glazed area required in Section 402.1.

Exception: Where rooms and spaces without openings to the outdoors are ventilated through an adjoining room, the unobstructed opening to the adjoining room shall be at least 8 percent of the floor area of the interior room or space, but a minimum of 25 square feet (2.33 m). The ventilation openings to the outdoors shall be based on a total floor area being ventilated.

403.2 Bathrooms and toilet rooms. Every bathroom and toilet room shall comply with the ventilation requirements for habitable spaces as required by Section 403.1, except that a window shall not be required in such spaces equipped with a mechanical ventilation system. Air exhausted by a mechanical ventilation system from a bathroom or toilet room shall discharge to the outdoors and shall not be recirculated.

403.3 Cooking facilities. Unless approved through the certificate of occupancy, cooking shall not be permitted in any rooming unit or dormitory unit, and a cooking facility or appliance shall not be permitted to be present in the rooming unit or dormitory unit.

Exceptions:

1. Where specifically approved in writing by the code official.
2. Devices such as coffee pots and microwave ovens shall not be considered cooking appliances.

403.4 Process ventilation. Where injurious, toxic, irritating or noxious fumes, gases, dusts or mists are generated, a local exhaust ventilation system shall be provided to remove the contaminating agent at the source. Air shall be exhausted to the exterior and not be recirculated to any space.

403.5 Clothes dryer exhaust. Clothes dryer exhaust systems shall be independent of all other systems and shall be exhausted outside the structure in accordance with the manufacturer's instructions.

Exception: Listed and labeled condensing (ductless) clothes dryers.

**SECTION 404
OCCUPANCY LIMITATIONS**

404.1 Privacy. Dwelling units, hotel units, housekeeping units, rooming units and dormitory units shall be arranged to provide privacy and be separate from other adjoining spaces.

404.2 Minimum room widths. A habitable room, other than a kitchen, shall be a minimum of 7 feet (2134 mm) in any plan dimension. Kitchens shall have a minimum clear passageway of 3 feet (914 mm) between counter fronts and appliances or counter fronts and walls.

404.3 Minimum ceiling heights. Habitable spaces, hall- ways, corridors, laundry areas, bathrooms, toilet rooms and habitable basement areas shall have a minimum clear ceiling height of 7 feet (2134 mm).

Exceptions:

1. In one- and two-family dwellings, beams or girders spaced a minimum of 4 feet (1219 mm) on center and projecting a maximum of 6 inches (152 mm) below the required ceiling height.
2. Basement rooms in one- and two-family dwellings occupied exclusively for laundry, study or recreation purposes, having a minimum ceiling height of 6 feet 8 inches (2033 mm) with a minimum clear height of 6 feet 4 inches (1932 mm) under beams, girders, ducts and similar obstructions.
3. Rooms occupied exclusively for sleeping, study or similar purposes and having a sloped ceiling over all or part of the room, with a minimum clear ceiling height of 7 feet (2134 mm) over a minimum of one- third of the required minimum floor area. In calculating the floor area of such rooms, only those portions of the floor area with a minimum clear ceiling height of 5 feet (1524 mm) shall be included.

404.4 Bedroom and living room requirements. Every bedroom and living room shall comply with the requirements of Sections 404.4.1 through 404.4.5.

404.4.1 Room area. Every living room shall contain at least 120 square feet (11.2 m2) and every bedroom shall contain a minimum of 70 square feet (6.5 m2) and every bedroom occupied by more than one person shall contain a minimum of 50 square feet (4.6 m2) of floor area for each occupant thereof.

404.4.2 Access from bedrooms. Bedrooms shall not constitute the only means of access to other bedrooms or habitable spaces and shall not serve as the only means of egress from other habitable spaces.

Exception: Units that contain fewer than two bed- rooms.

404.4.3 Water closet accessibility. Every bedroom shall have access to at least one water closet and one lavatory without passing through another bedroom. Every bedroom in a dwelling unit shall have access to at least one water closet and lavatory located in the same story as the bed- room or an adjacent story.

404.4.4 Prohibited occupancy. Kitchens and non-habitable spaces shall not be used for sleeping purposes.

404.4.5 Other requirements. Bedrooms shall comply with the applicable provisions of this code including, but not limited to, the light, ventilation, room area, ceiling height and room width requirements of this chapter; the plumbing facilities and water-heating facilities requirements of Chapter 5; the heating facilities and electrical receptacle requirements of Chapter 6; and the smoke detector and emergency escape requirements of Chapter 7.

404.5 Overcrowding. Dwelling units shall not be occupied by more occupants than permitted by the minimum area (requirements of Table 404.5).

**TABLE 404.5
MINIMUM AREA REQUIREMENTS**

SPACE	MINIMUM AREA IN SQUARE FEET		
	1-2 occupants	3-5 occupants	6+ occupants
Living room ^{a,b}	120	120	150
Dining room ^{a,b}	No requirement	80	100
Bedrooms	Shall comply with Section 404.4.1		

For SI: 1 square foot = 0.093 m²

a. See Section 404.5.2 for combined living room/dining room spaces.

b. See Section 404.5.1 for limitations on determining the minimum occupancy area for sleeping purposes.

404.5.1 Sleeping area. The minimum occupancy area required by Table 404.5 shall not be included as a sleeping area in determining the minimum occupancy area for sleeping purposes. All sleeping areas shall comply with Section 404.4.

404.5.2 Combined spaces. Combined living room and dining room spaces shall comply with the requirements of Table 404.5 if the total area is equal to that required for separate rooms and if the space is located so as to function as a combination living room/dining room.

404.6 Efficiency unit. Nothing in this section shall prohibit an efficiency living unit from meeting the following requirements:

1. A unit occupied by not more than one occupant shall have a minimum clear floor area of 120 square feet (11.2 m2). A unit occupied by not more than two occupants shall have a minimum clear floor area of 220 square feet (20.4 m2). A unit occupied by three occupants shall have a minimum clear floor area of 320 square feet (29.7 m2). These required areas shall be exclusive of the areas required by Items 2 and 3.

LIGHT, VENTILATION AND OCCUPANCY LIMITATIONS

2. The unit shall be provided with a kitchen sink, cooking appliance and refrigeration facilities, each having a minimum clear working space of 30 inches (762 mm) in front. Light and ventilation conforming to this code shall be provided.
3. The unit shall be provided with a separate bathroom containing a water closet, lavatory and bathtub or shower.
4. The maximum number of occupants shall be three.

404.7 Food preparation. All spaces to be occupied for food preparation purposes shall contain suitable space and equipment to store, prepare and serve foods in a sanitary manner. There shall be adequate facilities and services for the sanitary disposal of food wastes and refuse, including facilities for temporary storage.

CHAPTER 5

PLUMBING FACILITIES AND FIXTURE REQUIREMENTS

SECTION 501 GENERAL

501.1 Scope. The provisions of this chapter shall govern the minimum plumbing systems, facilities and plumbing fixtures to be provided.

501.2 Responsibility. The owner of the structure shall provide and maintain such plumbing facilities and plumbing fixtures in compliance with piece requirements. A person shall not occupy as owner-occupant or permit another person to occupy any structure or premises which does not comply with the requirements of this chapter.

SECTION 502 REQUIRED FACILITIES

[P] 502.1 Dwelling units. Every dwelling unit shall contain its own bathtub or shower, lavatory, water closet and kitchen sink which shall be maintained in a sanitary, safe working condition. The lavatory shall be placed in the same room as the water closet or located in close proximity to the door leading directly into the room in which such water closet is located. A kitchen sink shall not be used as a substitute for the required lavatory.

[P] 502.2 Rooming houses. At least one water closet, lavatory and bathtub or shower shall be supplied for each four rooming units.

[P] 502.3 Hotels. Where private water closets, lavatories and baths are not provided, one water closet, one lavatory and one bathtub or shower having access from a public hallway shall be provided for each ten occupants.

[P] 502.4 Employees' facilities. A minimum of one water closet, one lavatory and one drinking facility shall be available to employees.

[P] 502.4.1 Drinking facilities. Drinking facilities shall be a drinking fountain, water cooler, bottled water cooler or disposable cups next to a sink or water dispenser. Drinking facilities shall not be located in toilet rooms or bathrooms.

[P] 502.5 Public toilet facilities. Public toilet facilities shall be maintained in a safe sanitary and working condition in accordance with the International Plumbing Code. Except for periodic maintenance or cleaning, public access and use shall be provided to the toilet facilities at all times during occupancy of the premises.

SECTION 503 TOILET ROOMS

[P] 503.1 Privacy. Toilet rooms and bathrooms shall provide privacy and shall not constitute the only passageway to a hall or other space, or to the exterior. A door and interior locking device shall be provided for all common or shared bathrooms and toilet rooms in a multiple dwelling.

[P] 503.2 Location. Toilet rooms and bathrooms serving hotel units, rooming units or dormitory units or housekeeping units, shall have access by traversing a maximum of one flight of stairs and shall have access from a common hall or passageway.

[P] 503.3 Location of employee toilet facilities. Toilet facilities shall have access from within the employees' working area. The required toilet facilities shall be located a maximum of one story above or below the employees' working area and the path of travel to such facilities shall not exceed a distance of 500 feet (152 m). Employee facilities shall either be separate facilities or combined employee and public facilities.

Exception: Facilities that are required for employees in storage structures or kiosks, which are located in adjacent structures under the same ownership, lease or control, shall not exceed a travel distance of 500 feet (152 m) from the employees' regular working area to the facilities.

[P] 503.4 Floor surface. In other than dwelling units, every toilet room floor shall be maintained to be a smooth, hard, nonabsorbent surface to permit such floor to be easily kept in a clean and sanitary condition.

SECTION 504 PLUMBING SYSTEMS AND FIXTURES

[P] 504.1 General. All plumbing fixtures shall be properly installed and maintained in working order, and shall be kept free from obstructions, leaks and defects and be capable of performing the function for which such plumbing fixtures are designed. All plumbing fixtures shall be maintained in a safe, sanitary and functional condition.

[P] 504.2 Fixture clearances. Plumbing fixtures shall have adequate clearances for usage and cleaning.

[P] 504.3 Plumbing system hazards. Where it is found that a plumbing system in a structure constitutes a hazard to the occupants or the structure by reason of inadequate service, inadequate venting, cross connection, back siphonage, improper installation, deterioration or damage or for similar reasons, the code official shall require the defects to be corrected to eliminate the hazard.

PLUMBING FACILITIES AND FIXTURE REQUIREMENTS

SECTION 505 WATER SYSTEM

505.1 General. Every sink, lavatory, bathtub or shower, drinking fountain, water closet or other plumbing fixture shall be properly connected to either a public water system or to an approved private water system. All kitchen sinks, lavatories, laundry facilities, bathtubs and showers shall be supplied with hot or tempered and cold running water in accordance with the International Plumbing Code.

[P] 505.2 Contamination. The water supply shall be maintained free from contamination, and all water inlets for plumbing fixtures shall be located above the flood-level rim of the fixture. Shampoo basin faucets, janitor sink faucets and other hose bibs or faucets to which hoses are attached and left in place, shall be protected by an approved atmospheric-type vacuum breaker or an approved permanently attached hose connection vacuum breaker.

505.3 Supply. The water supply system shall be installed and maintained to provide a supply of water to plumbing fixtures, devices and appurtenances in sufficient volume and at pressures adequate to enable the fixtures to function properly, safely, and free from defects and leaks.

505.4 Water heating facilities. Water heating facilities shall be properly installed, maintained and capable of providing an adequate amount of water to be drawn at every required sink, lavatory, bathtub, shower and laundry facility at a minimum temperature of 110°F (43°C). A gas-burning water heater shall not be located in any bathroom, toilet room, bedroom or other occupied room normally kept closed, unless adequate combustion air is provided. An approved combination temperature and pressure-relief valve and relief valve discharge pipe shall be properly installed and maintained on water heaters.

SECTION 506 SANITARY DRAINAGE SYSTEM

[P] 506.1 General. All plumbing fixtures shall be properly connected to either public sewer system or to an approved private sewage disposal system.

[P] 506.2 Maintenance. Every plumbing stack, vent, waste and sewer line shall function properly and be kept free from obstructions, leaks and defects.

[P] 506.3 Grease interceptors. Grease interceptors and automatic grease removal devices shall be maintained in accordance with this code and the manufacturer's installation instructions. Grease interceptors and automatic grease removal devices shall be regularly serviced and cleaned to prevent the discharge of oil, grease, and other substances harmful or hazardous to the building drainage system, the public sewer, the private sewage disposal system or the sewage treatment plant or processes. All records of maintenance, cleaning and repairs shall be available for inspection by the code official.

SECTION 507 STORM DRAINAGE

[P] 507.1 General. Drainage of roofs and paved areas, yards and courts, and other open areas on the premises shall not be discharged in a manner that creates a public nuisance.

CHAPTER 6

MECHANICAL AND ELECTRICAL REQUIREMENTS

SECTION 601 GENERAL

601.1 Scope. The provisions of this chapter shall govern the minimum mechanical and electrical facilities and equipment to be provided.

601.2 Responsibility. The owner of the structure shall provide and maintain mechanical and electrical facilities and equipment in compliance with these requirements. A person shall not occupy as owner-occupant or permit another person to occupy any premises which does not comply with the requirements of this chapter.

SECTION 602 HEATING FACILITIES

602.1 Facilities required. Heating facilities shall be provided in structures as required by this section.

602.2 Residential occupancies. Dwellings shall be provided with heating facilities capable of maintaining a room temperature of 68°F (20°C) in all habitable rooms, bathrooms and toilet rooms based on the winter outdoor design temperature for the locality indicated in Appendix D of the International Plumbing Code. Cooking appliances shall not be used, nor shall portable unvented fuel-burning space heaters be used, as a means to provide required heating.

Exception: In areas where the average monthly temperature is above 30°F (-1°C), a minimum temperature of 65°F (18°C) shall be maintained.

602.3 Heat supply. *Every owner and operator of any building who rents, leases or lets one or more dwelling unit, rooming unit, dormitory or guestroom on terms, either express or implied, to furnish heat to the occupants thereof shall supply sufficient heat throughout the year to maintain the room temperatures specified in section 602.2 in all habitable rooms, bathrooms, and toilet rooms during the hours between 6:30 a.m. and 10:30 p.m. of each day and not less than 60 degrees F (16 degrees C) during other hour*

602.4 Occupiable work spaces. *Every enclosed occupied work space shall be supplied with sufficient heat throughout the year to maintain a temperature of not less than 65 degrees F (18 degrees C) during all working hours*

Exceptions:

a. Processing, storage and operation areas that require cooling or special temperature conditions.

b. Areas in which persons are primarily engaged in vigorous physical activities

602.5 Room temperature measurement. The required room temperatures shall be measured 3 feet (914 mm) above the floor near the center of the room and 2 feet (610 mm) inward from the center of each exterior wall.

SECTION 603 MECHANICAL EQUIPMENT

603.1 Mechanical appliances. All mechanical appliances, fireplaces, solid fuel-burning appliances, cooking appliances and water heating appliances shall be properly installed and maintained in a safe working condition, and shall be capable of performing the intended function.

603.2 Removal of combustion products. All fuel-burning equipment and appliances shall be connected to an approved chimney or vent.

Exception: Fuel-burning equipment and appliances which are labeled for unvented operation.

603.3 Clearances. All required clearances to combustible materials shall be maintained.

603.4 Safety controls. All safety controls for fuel-burning equipment shall be maintained in effective operation.

603.5 Combustion air. A supply of air for complete combustion of the fuel and for ventilation of the space containing the fuel-burning equipment shall be provided for the fuel-burning equipment.

603.6 Energy conservation devices. Devices intended to reduce fuel consumption by attachment to a fuel-burning appliance, to the fuel supply line thereto, or to the vent outlet or vent piping therefrom, shall not be installed unless labeled for such purpose and the installation is specifically approved.

SECTION 604 ELECTRICAL FACILITIES

604.1 Facilities required. Every occupied building shall be provided with an electrical system in compliance with the requirements of this section and Section 605.

604.2 Service. The size and usage of appliances and equipment shall serve as a basis for determining the need for additional

MECHANIC AND ELECTRICAL REQUIREMENTS

facilities in accordance with NFPA 70. Dwelling units shall be served by a three-wire, 120/240 volt, single-phase electrical service having a minimum rating of 60 amperes.

604.3 Electrical system hazards. Where it is found that the electrical system in a structure constitutes a hazard to the occupants or the structure by reason of inadequate service, improper fusing, insufficient receptacle and lighting outlets, improper wiring or installation, deterioration or damage, or for similar reasons, the code official shall require the defects to be corrected to eliminate the hazard.

604.3.1 Abatement of electrical hazards associated with water exposure. The provisions of this section shall govern the repair and replacement of electrical systems and equipment that have been exposed to water.

604.3.1.1 Electrical equipment. Electrical distribution equipment, motor circuits, power equipment, transformers, wire, cable, flexible cords, wiring devices, ground fault circuit interrupters, surge protectors, molded case circuit breakers, low-voltage fuses, luminaires, ballasts, motors and electronic control, signaling and communication equipment that have been exposed to water shall be replaced in accordance with the provisions of the International Building Code.

Exception: The following equipment shall be allowed to be repaired where an inspection report from the equipment manufacturer or approved manufacturer's representative indicates that the equipment has not sustained damage that requires replacement:

1. Enclosed switches, rated a maximum of 600 volts or less;
2. Busway, rated a maximum of 600 volts;
1. Panel boards, rated a maximum of 600 volts;
2. Switchboards, rated a maximum of 600 volts;
3. Fire pump controllers, rated a maximum of 600 volts;
4. Manual and magnetic motor controllers;
5. Motor control centers;
6. Alternating current high-voltage circuit breakers;
7. Low-voltage power circuit breakers;
8. Protective relays, meters and current transformers;
9. Low- and medium-voltage switchgear;
10. Liquid-filled transformers;
11. Cast-resin transformers;

12. Wire or cable that is suitable for wet locations and whose ends have not been exposed to water;
13. Wire or cable, not containing fillers, that is suitable for wet locations and whose ends have not been exposed to water;
14. Luminaires that are listed as submersible;
15. Motors;
16. Electronic control, signaling and communication equipment.

603.2 Abatement of electrical hazards associated with fire exposure. The provisions of this section shall govern the repair and replacement of electrical systems and equipment that have been exposed to fire.

603.2.1 Electrical equipment. Electrical switches, receptacles and fixtures, including furnace, water heating, security system and power distribution circuits that have been exposed to fire, shall be replaced in accordance with the provisions of the International Building Code.

Exception: Electrical switches, receptacles and fixtures that shall be allowed to be repaired where an inspection report from the equipment manufacturer or approved manufacturer's representative indicates that the equipment has not sustained damage that requires replacement.

SECTION 605 ELECTRICAL EQUIPMENT

605.1 Installation. All electrical equipment, wiring and appliances shall be properly installed and maintained in a safe and approved manner.

605.2 Receptacles. Every habitable space in a dwelling shall contain at least two separate and remote receptacle outlets. Every laundry area shall contain at least one grounding-type receptacle or a receptacle with a ground fault circuit interrupter. Every bathroom shall contain at least one receptacle. Any new bathroom receptacle outlet shall have ground fault circuit interrupter protection. All receptacle outlets shall have the appropriate faceplate cover for the location.

605.3 Luminaires. Every public hall, interior stairway, toilet room, kitchen, bathroom, laundry room, boiler room and furnace room shall contain at least one electric luminaire. Pool and spa luminaires over 15 V shall have ground fault circuit interrupter protection.

605.4 Wiring. Flexible cords shall not be used for permanent wiring, or for running through doors, windows, or cabinets, or concealed within walls, floors, or ceilings.

SECTION 606

ELEVATORS, ESCALATORS AND DUMBWAITERS

606.1 General. Elevators, dumbwaiters and escalators shall be maintained in compliance with ASME A17.1. The most current certificate of inspection shall be on display at all times within the elevator or attached to the escalator or dumb-waiter, be available for public inspection in the office of the building operator or be posted in a publicly conspicuous location approved by the code official. The inspection and tests shall be performed at not less than the periodic intervals listed in ASME A17.1, Appendix N, except where otherwise specified by the authority having jurisdiction.

606.2 Elevators. In buildings equipped with passenger elevators, at least one elevator shall be maintained in operation at all times when the building is occupied.

Exception: Buildings equipped with only one elevator shall be permitted to have the elevator temporarily out of service for testing or servicing.

**SECTION 607
DUCT SYSTEMS**

607.1 General. Duct systems shall be maintained free of obstructions and shall be capable of performing the required function.

CHAPTER 7

FIRE SAFETY REQUIREMENTS

SECTION 701 GENERAL

701.1 Scope. The provisions of this chapter shall govern the minimum conditions and standards for fire safety relating to structures and exterior premises, including fire safety facilities and equipment to be provided.

701.2 Responsibility. The owner of the premises shall provide and maintain such fire safety facilities and equipment in compliance with these requirements. A person shall not occupy as owner-occupant or permit another person to occupy any premises that do not comply with the requirements of this chapter.

SECTION 702 MEANS OF EGRESS

[F] 702.1 General. A safe, continuous and unobstructed path of travel shall be provided from any point in a building or structure to the public way. Means of egress shall comply with the International Fire Code.

[F] 702.2 Aisles. The required width of aisles in accordance with the International Fire Code shall be unobstructed.

[F] 702.3 Locked doors. All means of egress doors shall be readily openable from the side from which egress is to be made without the need for keys, special knowledge or effort, except where the door hardware conforms to that permitted by the International Building Code.

[F] 702.4 Emergency escape openings. Required emergency escape openings shall be maintained in accordance with the code in effect at the time of construction, and the following. Required emergency escape and rescue openings shall be operational from the inside of the room without the use of keys or tools. Bars, grilles, grates or similar devices are permitted to be placed over emergency escape and rescue openings provided the minimum net clear opening size complies with the code that was in effect at the time of construction and such devices shall be releasable or removable from the inside without the use of a key, tool or force greater than that which is required for normal operation of the escape and rescue opening.

SECTION 703 FIRE-RESISTANCE RATINGS

[F] 703.1 Fire-resistance-rated assemblies. The required fire-resistance rating of fire-resistance-rated walls, fire stops, shaft enclosures, partitions and floors shall be maintained.

[F] 703.2 Opening protectives. Required opening protectives shall be maintained in an operative condition. All fire and smoke stop doors shall be maintained in operable condition. Fire doors and smoke barrier doors shall not be blocked or obstructed or otherwise made inoperable.

SECTION 704 FIRE PROTECTION SYSTEMS

[F] 704.1 General. All systems, devices and equipment to detect a fire, actuate an alarm, or suppress or control a fire or any combination thereof shall be maintained in an operable condition at all times in accordance with the International Fire Code.

[F] 704.1.1 Automatic sprinkler systems. Inspection, testing and maintenance of automatic sprinkler systems shall be in accordance with NFPA 25.

[F] 704.2 Smoke alarms. Single- or multiple-station smoke alarms shall be installed and maintained in Group R or 1-1 occupancies, regardless of occupant load at all of the following locations:

1. On the ceiling or wall outside of each separate sleeping area in the immediate vicinity of bedrooms.
2. In each room used for sleeping purposes.
3. In each story within a dwelling unit, including basements and cellars but not including crawl spaces and uninhabitable attics. In dwellings or dwelling units with split levels and without an intervening door between the adjacent levels, a smoke alarm installed on the upper level shall suffice for the adjacent lower level provided that the lower level is less than one full story below the upper level.

[F] 704.3 Power source. In Group R or 1-1 occupancies, single-station smoke alarms shall receive their primary power from the building wiring provided that such wiring is served from a commercial source and shall be equipped with a battery backup. Smoke alarms shall emit a signal when the batteries are low. Wiring shall be permanent and without a disconnecting switch other than as required for overcurrent protection.

Exception: Smoke alarms are permitted to be solely battery operated in buildings where no construction is taking place, buildings that are not served from a commercial power source and in existing areas of buildings undergoing alterations or repairs that do not result in the removal of interior wall or ceiling finishes exposing the structure, unless there is an attic, crawl space or basement available which could provide access for building wiring without the removal of interior finishes.

[F] 704.4 Interconnection. Where more than one smoke alarm is required to be installed within an individual dwelling unit in Group R or 1-1 occupancies, the smoke alarms shall be interconnected in such a manner that the activation of one alarm will activate all of the alarms in the individual unit. Physical interconnection of smoke alarms shall not be required where listed wireless alarms are installed and all alarms sound upon activation of one alarm. The alarm shall be clearly audible in all bedrooms over background noise levels with all intervening doors closed.

Exceptions:

1. Interconnection is not required in buildings which are not undergoing alterations, repairs or construction of any kind.
2. Smoke alarms in existing areas are not required to be interconnected where alterations or repairs do not result in the removal of interior wall or ceiling finishes exposing the structure, unless there is an attic, crawl space or basement available which could provide access for interconnection without the removal of interior finishes.

APPENDIX A

BOARDING STANDARD

The provisions contained in this appendix are not mandatory unless specifically referenced in the adopting ordinance.

A101 GENERAL

A101.1 General. All windows and doors shall be boarded in an *approved* manner to prevent entry by unauthorized persons and shall be painted to correspond to the color of the existing structure.

A102 MATERIALS

A102.1 Boarding sheet material. Boarding sheet material shall be minimum $\frac{1}{2}$ -inch (12.7 mm) thick wood structural panels complying with the *International Building Code*.

A102.2 Boarding framing material. Boarding framing material shall be minimum nominal 2-inch by 4-inch (51 mm by 102 mm) solid sawn lumber complying with the *International Building Code*.

A102.3 Boarding fasteners. Boarding fasteners shall be minimum $\frac{3}{8}$ -inch (9.5 mm) diameter carriage bolts of such a length as required to penetrate the assembly and as required to adequately attach the washers and nuts. Washers and nuts shall comply with the *International Building Code*.

A103 INSTALLATION

A103.1 Boarding installation. The boarding installation shall be in accordance with Figures A103.1(1) and A103.1(2) and Sections A103.2 through A103.5.

A103.2 Boarding sheet material. The boarding sheet material shall be cut to fit the door or window opening neatly or shall be cut to provide an equal overlap at the perimeter of the door or window.

A103.3 Windows. The window shall be opened to allow the carriage bolt to pass through or the window sash shall be removed and stored. The 2-inch by 4-inch (51 mm by 102 mm) strong back framing material shall be cut minimum 2 inches (51 mm) wider than the window opening and shall be placed on the inside of the window opening 6 inches minimum above the bottom and below the top of the window opening. The framing and boarding shall be predrilled. The assembly shall be aligned and the bolts, washers and nuts shall be installed and secured.

A103.4 Door walls. The door opening shall be framed with minimum 2-inch by 4-inch (51 mm by 102 mm) framing material secured at the entire perimeter and vertical members at a maximum of 24 inches (610 mm) on center. Blocking shall also be secured at a maximum of 48 inches (1219 mm) on center vertically. Boarding sheet material shall be secured

with screws and nails alternating every 6 inches (152 mm) on center.

A103.5 Doors. Doors shall be secured by the same method as for windows or door openings. One door to the structure shall be available for authorized entry and shall be secured and locked in an *approved* manner.

A104 REFERENCED STANDARDS

IBC—12 International Building Code A102.1, A102.2, A102.3

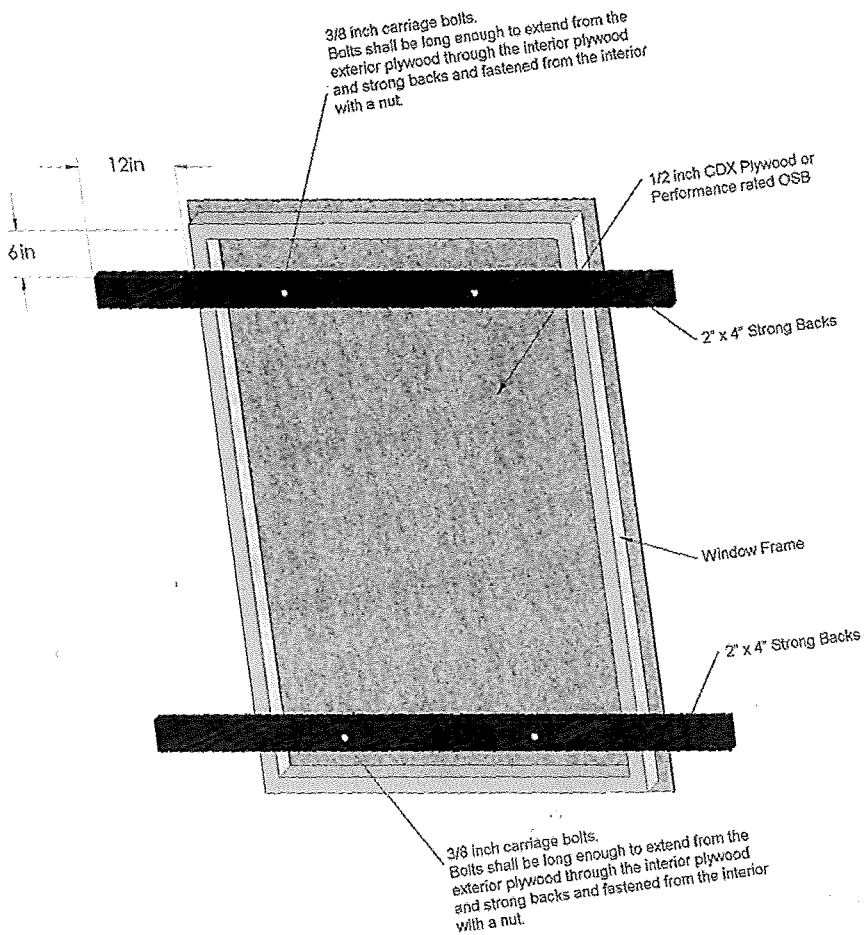

FIGURE A103.1(1)
BOARDING OF DOOR OR WINDOW

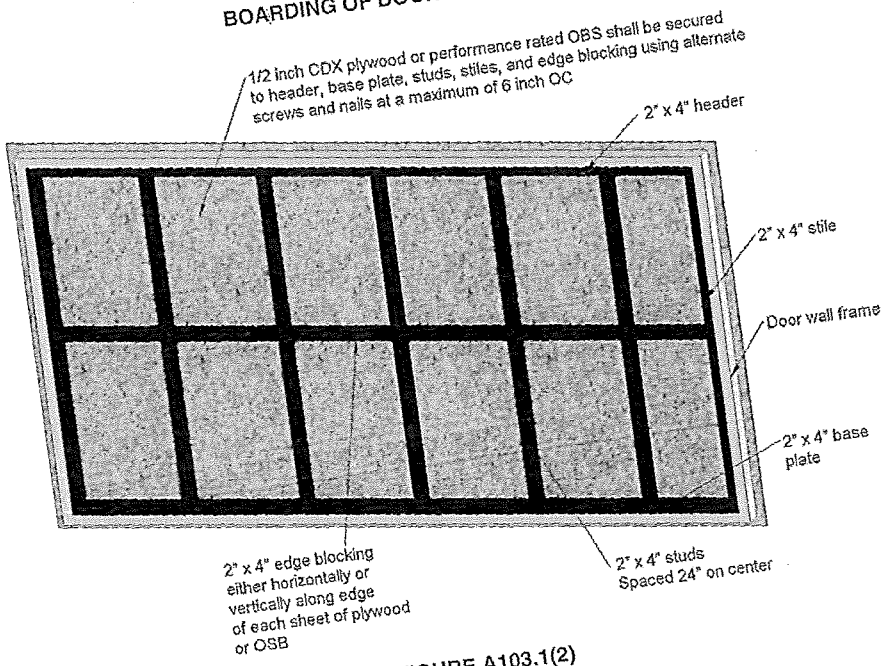

FIGURE A103.1(2)
BOARDING OF DOOR WALL

INDEX

A

ACCESS

- Emergency egress 702
- From bedrooms 404.4.2
- Plumbing fixtures, access for cleaning 504.2
- To public way 702.1
- Toilet room as passageway 503.1
- Water closet 404.4.3

ADJACENT

- Privacy (hotel units, rooming units) 404.1

ADMINISTRATION

- Scope 101.2

AGENT (See also OPERATOR, OWNER)

- Definition 202

AIR

- Combustion air 603.5

AISLES

- Minimum width 702.2

ALTERATION

- Applicability of other codes 102.3
- Inspection 104.2
- Prosecution 106.3
- Unlawful acts 106.1

ANCHOR

- Anchored, definition 202
- Architectural trim 304.8
- Signs, marquees and awnings 304.9
- Unsafe conditions 304.1.1

APPEAL

- Application 111.1
- Board decision 111.6
- Board of appeals 111.2
- Court review 111.7
- Disqualification 111.2.3
- Financial interest 111.2.3
- Hearing, emergency orders 109.6
- Membership 111.2
- Notice of appeal 111.1
- Postponed hearing 111.5
- Records 104.6
- Right to appeal 111.1
- Vote 111.6

APPLIANCE

- Cooking 403.3, 602.2
- Mechanical 603.1

APPLICABILITY

- Application of references 102.9

- General 102.1
- Other laws 102.10
- Referenced codes and standards 102.7

APPROVAL

- Alternatives 105.2
- Authority 104.1, 105.2
- Modifications 105.1
- Research reports 105.6
- Used material and equipment 105.4

APPROVED

- Alternative materials, methods and equipment 105.2
- Definition 202
- Energy conservation devices 603.6
- Garbage storage facilities 308.3.1
- Modifications 105.1
- Used materials and equipment 105.4

ARTIFICIAL

- Lighting of habitable rooms 401.3
- Lighting of other spaces 402.3

AUTOMOBILE

- Motor vehicles 302.8

AWNING

- Signs, marquees and awnings 304.9

B

BALCONY

- Handrails and guardrails 304.12

BASEMENT

- Definition 202
- Hatchways 304.16
- Windows 304.17

BATHROOM

- Common bathrooms 502.3, 503.1
- Hotels 502.3
- Lighting 605.3
- Locks 503.1
- Outlets required 605.2
- Privacy 503.1
- Ventilation 403.2

BATHTUB

- Dwelling units 502.1
- Rooming houses 502.2
- Sewage system 506.1
- Water-heating facilities 505.4
- Water system 505.1

BOARDING

Boarding standard Appendix A

BOILER

Unsafe equipment 108.1.2

C

CAPACITY

Heating facilities 602.2, 602.3, 602.4

CAR (See AUTOMOBILE)

CEILING

Basement rooms 404.3
 Fire-resistance ratings 703.1
 Interior surfaces 305.3
 Minimum height 404.3
 Sleeping rooms 404.3

CHANGE, MODIFY

Application of other codes 102.3

CHIMNEY

Exterior structure 304.11
 Flue 603.2, 603.3

CLEANING

Access for cleaning 504.2
 Disposal of garbage 308.3
 Disposal of rubbish 308.2
 Interior and exterior sanitation 308.1
 Interior surfaces 305.3
 Plumbing facilities, maintained 504.1
 Required plumbing facilities 502
 Responsibility of persons 305.1
 Trash containers 308.3.2
 Vacant structures and land 301.3

CLEARANCE

Heating facilities 603.3
 Plumbing fixtures 504.2

CLOSING

Streets 109.3
 Vacant structures 108.2

CLOTHES DRYER

Exhaust 403.5

CODE OFFICIAL

Condemnation 108.1
 Demolition 110
 Duties 104
 Emergency order 109
 Enforcement authority 104.1
 Failure to comply with demolition order 110.3
 Identification 104.3
 Inspections 104.2
 Liability, relief of personal 103.4
 Membership of board of appeals 111.2
 Notice of violation 104.5, 107

Notices and orders 107
 Official records 104.6
 Personal liability 103.4
 Placarding 108.4
 Prosecution 106.3
 Removal of placard 108.4.1
 Right of entry 104.3
 Transfer of ownership 107.6
 Vacant structures 108.2
 Voting of appeals board 111.2, 111.6

COMBUSTION

Combustion air 603.5

COMPONENT SERVICEABILITY

Unsafe conditions 306.1.1

CONDEMNATION

Closing of vacant structures 108.2
 Failure to comply 110.3
 General 108.1
 Notices and orders 108.2, 108.3
 Placarding 108.4
 Removal of placard 108.4.1

CONFLICT

Conflict of interest 111.2.3
 Violations 106.1

CONNECTION

Sewage system 506.1
 Water heating 505.4
 Water system 505.1

CONSTRUCTION

Existing structures 101.2

CONTAINER

Garbage 308.3.2
 Rubbish storage 308.2.1

CONTINUOUS

Unobstructed egress 702.1

CONTROL

Rodent control 302.5, 304.5
 Safety controls 603.4
 Weed 302.4

COOLING

Cooling towers 304.11

CORRIDOR

Accumulation of rubbish 308.1
 Light 402.2
 Lighting fixtures 605.3
 Obstructions 702.1, 702.2
 Ratings maintained 703

D

DAMP, DAMPNES

Roofs 304.7

- Window, door frames304.13
- DANGEROUS, HAZARDOUS**
- Condemnation108.1
- Demolition 110
- Electrical hazards604.3, 604.3.1
- Existing remedies102.4
- Imminent danger 202
- Unsafe equipment 108.1.2
- Unsafe structures or premises 108.1.5
- DECKS**
- Handrails and guardrails304.12
- Maintenance 304.2, 304.10
- DEMOLITION**
- Existing remedies102.4
- Failure to comply110.3
- General 110
- Order110.2
- Salvage materials110.4
- DETECTORS**
- Smoke 704
- DETERIORATION**
- Components of systems 306.1.1
- Definition 202
- Exterior structure 304.1.1
- Exterior walls304.6
- DIRECT**
- Egress702.1
- DISPOSAL**
- Disposal of garbage308.3
- Disposal of rubbish308.2
- DOOR**
- Exit doors702.3
- Fire703.2
- Hardware304.15
- Insect screens304.14
- Interior surfaces305.3
- Locks 304.15, 702.3
- Maintenance 304.13, 304.15
- Weather tight304.13
- Window and door frames304.13
- DORMITORY (ROOMING HOUSE, HOTEL, MOTEL)**
- Locked doors702.3
- Privacy 503.1, 503.2
- DRAIN, DRAINAGE**
- Basement hatchways304.16
- Plumbing connections 506
- Storm drainage 507
- DUCT**
- Exhaust duct304.9
- Duct systems 607
- DUST**
- Process ventilation 403.4
- DWELLING**
- Cleanliness 305.1, 308.1
- Definition 202
- Electrical 604.1
- Heating facilities 602
- Required facilities 502
- E**
- EGRESS**
- Aisles 702.2
- Emergency escape 702.4
- General 702.1
- Lighting 402.2
- Locked doors 702.3
- Obstructions prohibited 702.1
- Stairs, porches and railings 304.10,
305.4, 305.5, 307.1
- ELECTRIC, ELECTRICAL EQUIPMENT**
- Abatement of hazards, fire exposure 604.3.2
- Abatement of hazards, water exposure 604.3.1
- Condemnation 108.1
- Electrical equipment 604.3.1.1
- Facilities required 604.1
- Hazards 604.3
- Installation 605.1
- Lighting fixtures 605.3
- Receptacles 604.3, 605.2
- Responsibility 601.2
- Service 604.2
- ELEVATOR, ESCALATORS, DUMBWAITERS**
- Condemnation 108.1
- General 606.1
- Maintenance 606.1, 606.2
- EMERGENCY**
- Emergency escape openings 702.4
- Emergency measures 109
- Emergency orders 109.1
- ENFORCEMENT**
- Duties and powers 104
- Scope 101.2
- EQUIPMENT**
- Alternative 105.2
- Combustion air 603.5
- Condemnation 108.1.2, 108.3
- Electrical installation 605.1
- Emergency order 109.1
- Energy conservation devices 603.6
- Installation 603.1

INDEX

Interior structure 305.1
Placarding 108.4, 108.5
Prohibited use 108.5
Responsibility 601.2
Safety controls 603.4
Scope 101.2
Scope, mechanical and electrical 601.1
Support, definition 202
Unsafe 108.1.2
Used 105.4

EXHAUST

Clothes dryer 403.5
Exhaust ducts 304.9
Process ventilation 403.4

EXISTING

Remedies 102.4
Scope 101.2
Structural members 304.1.1, 304.4
Structures 101.3

EXTERIOR

Decorative features 304.8
Exterior structure 304
Exterior walls 304.6
Painting 304.2, 304.6
Rodent harborage 302.5, 304.5
Sanitation 304.1
Scope 301.1
Stair 304.10
Street numbers 304.3
Unsafe conditions 304.1.1
Weather tight 304.13

F

FAN

Exhaust vents 302.6

FEES, EXPENSES, COST

Closing vacant structures 108.2
Demolition 110.1, 110.3, 110.4
Extermination 309.2, 309.3, 309.4, 309.5
General 103.5
Relief from personal liability 103.4

FENCE

Accessory 302.7
Maintenance 304.2

FIRE

Automatic sprinkler systems 704.1.1
Fire-resistance-rated assemblies 703.1
Fire protection systems 704
Responsibility, fire safety 701.2
Scope 101.2

Scope, fire safety 701.1
Smoke alarms 704.2

FLAMMABLE LIQUID

Containers 108.1.2

FLOOR, FLOORING

Area for sleeping purposes 404.4.1
Fire-resistance ratings 703.1
Interior surfaces 305.1, 305.3
Space requirements 404.4.1, 404.6

FOOD PREPARATION

Cooking equipment 403.3
Sanitary condition 305.1, 404.7
Ventilation 403.4

FOUNDATION

Condemnation 108.1.1
Foundation walls 304.5
Unsafe conditions 304.1.1, 305.1.1

FRAME

Window and door frames 304.13

G

GAS

Energy conservation devices 603.6
Exhaust vents 302.6

GLAZING

Materials 304.13.1

GRADE

Drainage 302.2, 507

GUARD

Anchorage and maintenance 304.12
Basement windows 304.18.2
Definition 202

H

HABITABLE

Definition 202
Light 402
Minimum ceiling height 404.3
Minimum room width 404.2
Required plumbing facilities 502
Residential heating facilities 602.2, 602.3
Space requirements 404.4.1
Ventilation 403

HANDRAILS AND GUARDRAILS

Handrails 304.12, 305.5, 307.1
Stairs and porches 304.10

HARDWARE

Door hardware 304.15, 702.3
Openable windows 304.13.2

HAZARDOUS (See DANGEROUS, HAZARDOUS)

HEAT, HEATING

- Energy conservation devices 603.6
- Fireplaces 603.1
- Heating 603.1
- Mechanical equipment 603.1
- Required capabilities 602
- Residential heating 602.2, 602.3
- Supply 602.3
- Water heating facilities 505.4
- Water system 505

HEIGHT

- Minimum ceiling height 404.3

HOT (See HEAT, HEATING)

HOTELS, ROOMING HOUSES AND DORMITORY UNITS, MOTELS

- Definition 202
- Locked doors 702.3
- Required facilities 502
- Toilet rooms 503

HOUSEKEEPING UNIT

- Definition 202

I

IDENTIFICATION

- Code official 104.4

INFESTATION

- Condemnation 108.1.3
- Definition 202
- Insect and rodent 302.5, 304.14, 309.1

INSECTS

- Infestation 309.1
- Insect screens 304.14
- Pest elimination 309

INSPECTIONS

- General 104.2
- Right of entry 104.3

INSPECTOR

- Identification 104.4
- Inspections 104.2
- Records 104.6

INTENT

- Code 101.3

INTERIOR

- Interior structure 305
- Interior surfaces 305.3
- Means of egress 702
- Sanitation 305.1
- Unsafe conditions 305.1.1

J

JURISDICTION

- Title 101.1

K

KITCHEN

- Electrical outlets required 605.2
- Minimum width 404.2
- Prohibited use 404.4.4
- Room lighting 605.3
- Water heating facilities 505.4

L

LANDING

- Handrails and guards 304.12, 305.5, 306.1
- Maintenance 304.10, 305.4

LAUNDRY

- Room lighting 605.3
- Water-heating facilities 505.4

LAVATORY

- Hotels 502.3
- Required facilities 502
- Rooming houses 502.2
- Sanitary drainage system 506
- Water-heating facilities 505.4
- Water system 505

LEASE (SELL, RENT)

- Heat supplied 602.3
- Salvage materials 110.4
- Transfer of ownership 107.6

LIEN

- Closing of vacant structures 108.2
- Demolition 110.3
- Failure to comply 110.3

LIGHT, LIGHTING

- Common halls and stairways 402.2, 605.3
- General 402
- Habitable rooms 402.1
- Kitchen 605.3
- Laundry rooms 605.3
- Luminaires 605.3
- Other spaces 402.3
- Responsibility 401.2
- Scope 101.2
- Toilet rooms 605.3

LIVING ROOM

- Room area 404.4.1

INDEX

LOAD, LOADING

- Elevators, escalators and dumbwaiters 606.1
- Handrails and guardrails 304.12, 305.5
- Live load 304.4, 305.2
- Stairs and porches 304.10, 305.2
- Structural members 304.4, 305.2

M

MAINTENANCE

- Required 102.2

MATERIAL

- Alternative 105.2
- Salvage 110.4
- Used 105.4

MEANS OF EGRESS (See EGRESS)

MECHANICAL

- Installation 603.1
- Responsibility 601.2
- Scope 601.1
- Ventilation, general 403
- Ventilation, toilet rooms 403.2

MINIMUM

- Ceiling height 404.3
- Room area 404.4.1
- Room width 404.2

MODIFICATION

- Approval 105.1

MOTEL (See HOTELS)

MOTOR VEHICLES

- Inoperative 302.8
- Painting 302.8

N

NATURAL

- Lighting 401.3, 402
- Ventilation 401.3, 403

NOTICES AND ORDERS

- Appeal 111.1
- Form 107.2
- Method of service 107.3
- Orders 107
- Owner, responsible person 107.1
- Penalties 107.5
- Placarding of structure 108.4
- Transfer of ownership 107.6
- Unauthorized tampering 107.4
- Vacating structure 108.2

NOXIOUS

- Process ventilation 403.4
- Weeds 302.4

NUISANCE

- Closing of vacant structures 108.2

O

OBSTRUCTION

- Light 402.1
- Right of entry 104.3

OCCUPANCY (See USE)

OPENABLE

- Locked doors 702.3
- Windows 304.13.2, 403.1

OPERATOR

- Definition 202

ORDER (See NOTICE)

ORDINANCE, RULE

- Applicability 102
- Application for appeal 111.1

OUTLET

- Electrical 605.2

OWNER

- Closing of vacant structures 108.2
- Definition 202
- Demolition 110
- Failure to comply 110.3
- Insect and rat control 302.5, 309.2, 309.4
- Notice 107.1, 108.3
- Pest elimination 309.2
- Placarding of structure 108.4
- Responsibility 301.2
- Responsibility, fire safety 701.2
- Responsibility, light, ventilation 401.2
- Responsibility, mechanical and electrical 601.2
- Responsibility, plumbing facilities 501.2
- Right of entry 104.3
- Rubbish storage 308.2.1
- Scope 101.2
- Transfer of ownership 107.6

P

PASSAGEWAY

- Common hall and stairway 402.2
- Interior surfaces 305.3
- Toilet rooms, direct access 503.1

PENALTY

- Notices and orders 107.5
- Placarding of structure 108.4
- Prohibited occupancy 108.5
- Removal of placard 108.4.1
- Scope 101.2
- Violations 106.4

PEST ELIMINATION

Condemnation	108.1
Definition	202
Insect and rodent control	302.5, 304.5, 304.14, 309.1
Pest elimination	309.1
Responsibility of owner	301.2, 309.2
Responsibility of tenant-occupant	309.3, 309.4, 309.5

PLACARD, POST

Closing	108.2
Condemnation	108.1
Demolition	110
Emergency, notice	109.1
Notice to owner	107.1, 108.3
Placarding of structure	108.4
Prohibited use	108.5
Removal	108.4.1

PLUMBING

Clean and sanitary	504.1
Clearance	504.2
Connections	505.1
Contamination	505.2
Employee's facilities	503.3
Fixtures	504.1
Required facilities	502
Responsibility	501.2
Sanitary drainage system	506
Scope	501.1
Storm drainage	507
Supply	505.3
Water heating facilities	505.4

PORCH

Handrails	304.12
Structurally sound	304.10

PORTABLE (TEMPORARY)

Cooking equipment	603.1
-----------------------------	-------

PRESSURE

Water supply	505.3
------------------------	-------

PRIVATE, PRIVACY

Bathtub or shower	503.1
Occupancy limitations	404.1
Required plumbing facilities	502
Sewage system	506.1
Water closet and lavatory	503.1
Water system	505.1

PROPERTY, PREMISES

Cleanliness	304.1, 308.1
Condemnation	108
Definition	202
Demolition	110
Emergency measures	109
Exterior areas	302

Failure to comply	110.3
Grading and drainage	302.2
Pest elimination, multiple occupancy	302.5, 309.4
Pest elimination, single occupancy	302.5, 309.3
Responsibility	301.2
Scope	301.1
Storm drainage	507
Vacant structures and land	301.3

PROTECTION

Basement windows	304.17
Fire protection systems	704
Signs, marquees and awnings	304.9

PUBLIC

Cleanliness	304.1, 305.1
Egress	702.1
Hallway	502.3
Sewage system	506.1
Toilet facilities	502.5, 503
Vacant structures and land	301.3
Water system	505

PUBLIC WAY

Definition	202
----------------------	-----

R**RAIN (PREVENTION OF ENTRY INTO BUILDING EXTERIOR ENVELOPE)**

Basement hatchways	304.16
Exterior walls	304.6
Grading and drainage	302.2
Roofs	304.7
Window and door frames	304.13

RECORD

Official records	104.6
----------------------------	-------

REPAIR

Application of other codes	102.3
Chimneys	304.11
Demolition	110.1
Exterior surfaces	304.1
Intent	101.3
Maintenance	102.2
Signs, marquees and awnings	304.9
Stairs and porches	304.10
Weather tight	304.13
Workmanship	102.5

REPORTS

Test reports	105.3.2
------------------------	---------

RESIDENTIAL

Pest elimination	309
Residential heating	602.2
Scope	101.2

RESPONSIBILITY

Pest elimination 309
 Fire safety 701.2
 Garbage disposal 308.3
 General 301.2
 Mechanical and electrical 601.2
 Persons 301.1
 Placarding of structure 108.4
 Plumbing facilities 501.2
 Rubbish storage 308.2.1
 Scope 101.2, 301.1

REVOKE, REMOVE

Demolition 110
 Existing remedies 102.4
 Removal of placard 108.4.1
 Rubbish removal 308.2.1

RIGHT OF ENTRY

Duties and powers of code official 104.3
 Inspections 104.2

RODENTS

Basement hatchways 304.16
 Condemnation 108
 Foundations 304.5
 Guards for basement windows 304.17
 Harborage 302.5
 Insect and rodent control 309.1
 Pest elimination 302.5, 309

ROOF

Exterior structure 304.1
 Roofs 304.7
 Storm drainage 507

ROOM

Bedroom and living room 404.4
 Cooking facilities 403.3
 Direct access 503.2
 Habitable 402.1
 Heating facilities 602
 Light 402
 Minimum ceiling heights 404.3
 Minimum width 404.2
 Overcrowding 404.5
 Prohibited use 404.4.4
 Temperature 602.5
 Toilet 503
 Ventilation 403

ROOMING HOUSES (See DORMITORY)

RUBBISH

Accumulation 308.1
 Definition 202

Disposal 308.2
 Garbage facilities 308.3.1
 Rubbish storage 308.2.1

S

SAFETY, SAFE

Fire safety requirements 701, 702, 703, 704
 Safety controls 603.4

SANITARY

Cleanliness 304.1, 305.1
 Disposal of garbage 308.3
 Disposal of rubbish 308.2
 Exterior property areas 302.1
 Exterior structure 304.1
 Food preparation 404.7
 Furnished by occupant 302.1
 Grease interceptors 506.3
 Interior surfaces 305.3
 Plumbing fixtures 504.1
 Required plumbing facilities 502
 Scope 101.2

SCREENS

Insect screens 304.14

SECURITY

Basement hatchways 304.18.3
 Building 304.18
 Doors 304.18.1
 Vacant structures and land 301.3
 Windows 304.18.2

SELF-CLOSING SCREEN DOORS

Insect screens 304.14

SEPARATION

Fire-resistance ratings 703
 Privacy 404.1
 Separation of units 404.1

SERVICE

Electrical 604.2
 Method 107.3
 Notices and orders 107.1, 108.3
 Service on occupant 108.3

SEWER

General 506.1
 Maintenance 506.2

SHOWER

Bathtub or shower 502.1
 Rooming houses 502.2
 Water-heating facilities 505.4
 Water system 505

- SIGN**
 Signs, marquees and awnings 304.9
 Unauthorized tampering 107.4
- SINGLE-FAMILY DWELLING**
 Extermination 309
- SINK**
 Kitchen sink 502.1
 Sewage system 506
 Water supply 505.3
- SIZE**
 Efficiency unit 404.6
 Habitable room, light 402
 Habitable room, ventilation 403
 Room area 404.4.1
- SMOKE**
 Alarms 704.2
 Interconnection 704.4
 Power source 704.3
- SPACE**
 General, light 402
 General, ventilation 403
 Occupancy limitations 404
 Privacy 404.1
 Scope 401.1
- STACK**
 Smoke 304.11
- STAIRS**
 Common halls and stairways, light 402.2
 Exit facilities 305.4
 Exterior property areas 302.3
 Handrails 304.12, 305.5
 Lighting 605.3
 Stairs and porches 304.10
- STANDARD**
 Referenced 102.7
- STOP WORK ORDER**
 Authority 112.1
 Emergencies 112.3
 Failure to comply 112.4
 Issuance 112.2
- STORAGE**
 Food preparation 404.7
 Garbage storage facilities 308.3
 Rubbish storage facilities 308.2.1
 Sanitation 308.1
- STRUCTURE**
 Accessory structures 302.7
 Closing of vacant structures 108.2
 Definition 202
 Emergency measures 109
 General, condemnation 110
 General, exterior 304.1
 General, interior structure 305.1
 Placarding of structure 108.4
 Scope 301.1
 Structural members 304.4, 305.2
 Vacant structures and land 301.3
- SUPPLY**
 Combustion air 603.5
 Public water system 505.1
 Water-heating facilities 505.4
 Water supply 505.3
 Water system 505
- SURFACE**
 Exterior surfaces 304.2, 304.6
 Interior surfaces 305.3
- SWIMMING**
 Enclosure 303.2
 Safety covers 303.2
 Swimming pools 303.1
- T**
- TEMPERATURE**
 Nonresidential structures 602.4
 Residential buildings 602.2
 Water-heating facilities 505.4
- TENANT**
 Scope 101.2
- TEST, TESTING**
 Agency 105.3.1
 Methods 105.3.1
 Reports 105.3.2
 Required 105.3
- TOXIC**
 Process ventilation 403.4
- TRASH**
 Rubbish and garbage 308
- U**
- UNOBSTRUCTED**
 Access to public way 702.1
 General, egress 702.1
- UNSAFE STRUCTURES AND EQUIPMENT**
 Abatement methods 108.6
 Dangerous structure or premises 108.1.5
 Equipment 108.1.2
 Existing remedies 102.4
 General, condemnation 108, 110
 General, demolition 110
 Notices and orders 107, 108.3
 Record 108.7

INDEX

Structures 108.1.1

USE

Application of other codes 102.3

General, demolition 110

UTILITIES

Authority to disconnect 108.2.1

V

VACANT

Abatement methods 108.6

Authority to disconnect service utilities 108.2.1

Closing of vacant structures 108.2

Emergency measure 109

Method of service 107.3, 108.3

Notice to owner or to
person responsible 107, 108.3

Placarding of structure 108.4

Record 108.7

Vacant structures and land 301.3

VAPOR

Exhaust vents 302.6

VEHICLES

Inoperative 302.8

Painting 302.8

VENT

Plumbing hazard 504.3

Exhaust vents 302.6

Flue 603.2

VENTILATION

Clothes dryer exhaust 403.5

Combustion air 603.5

Definition 202

General, ventilation 403

Habitable rooms 403.1

Process ventilation 403.4

Recirculation 403.2, 403.4

Toilet rooms 403.2

VERMIN

Condemnation 108

Insect and rodent control 302.5, 309

VIOLATION

Condemnation 108

General 106

Notice 107, 108.3

Penalty 106.4

Placarding of structure 108.4

Prosecution 106.3

Strict liability offense 106.3, 202

Transfer of ownership 107.6

W

WALK

Sidewalks 302.3

WALL

Accessory structures 302.7

Exterior surfaces 304.2, 304.6

Exterior walls 304.6

Foundation walls 304.5

General, fire-resistance rating 703.1

Interior surfaces 305.3

Outlets required 605.2

Temperature measurement 602.5

WASTE

Disposal of garbage 308.3

Disposal of rubbish 308.2

Garbage storage facilities 308.3.1

WATER

Basement hatchways 304.16

Connections 506.1

Contamination 505.2

General, sewage 506

General, storm drainage 507

General, water system 505

Heating 505.4

Hotels 502.3

Kitchen sink 502.1

Required facilities 502

Rooming houses 502.2

Supply 505.3

System 505

Toilet rooms 503

Water-heating facilities 505.4

WEATHER, CLIMATE

Heating facilities 602

WEEDS

Noxious weeds 302.4

WIDTH

Minimum room width 404.2

WINDOW

Emergency escape 702.4

Glazing 304.13.1

Guards for basement windows 304.17

Habitable rooms 402.1

Insect screens 304.14

Interior surface 305.3

Light 402

Openable windows 304.13.2

Toilet rooms 403.2

Ventilation 403

Weather tight304.13
Window and door frames304.13
WORKMANSHIP
General.....102.5

